

# ARCHITECTURAL DESIGN AND ACCESS STATEMENT

September 2018

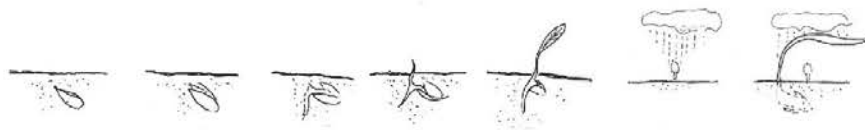

Proposed New Dwelling at Ampleforth

Revision - B

This document forms part of a Planning Application submission for a new dwelling in Ampleforth, dated September 2018.

All rights reserved. No part of this publication may be reproduced, distributed, or transmitted in any form or by any means, including photocopying, recording, or other electronic or mechanical methods, without prior written permission of the publisher, except in the case of brief quotations embodied in critical reviews and certain other noncommercial uses permitted by copyright law. For permission requests, write to the publisher, addressed "Attention: Permissions Coordinator," at the address below:

11/12 Riverside Studios  
Amethyst Road  
Newcastle upon Tyne  
NE4 7YL

e: [info@sadlerbrown.co.uk](mailto:info@sadlerbrown.co.uk)  
w: [www.sadlerbrown.co.uk](http://www.sadlerbrown.co.uk)

Newcastle (head office): 0191 265 7080

This document is intended for borderless, double-sided, left-hand-bound, A4 portrait, colour print.

SECTION A :  
INTRODUCTION

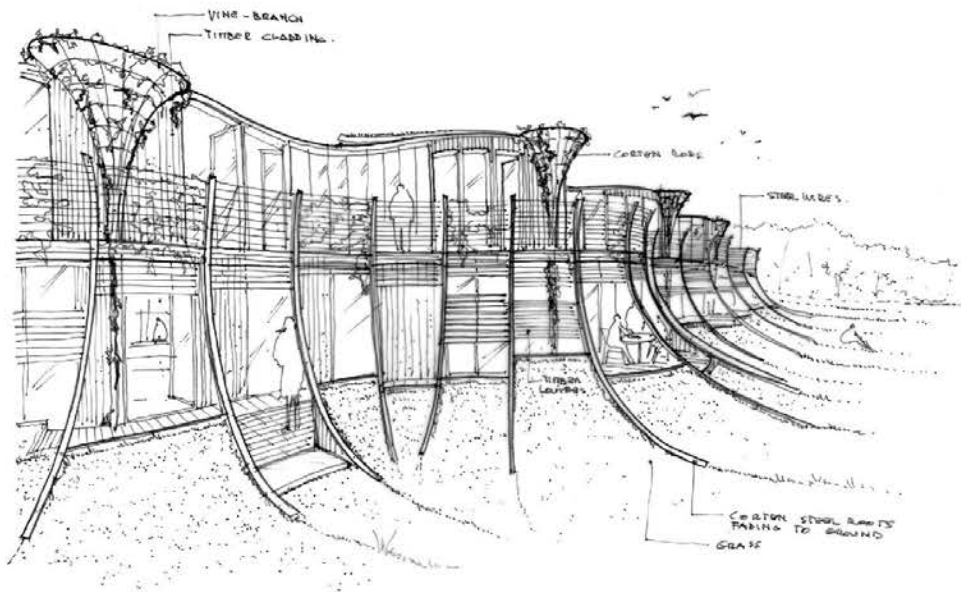

Development sketch of the proposed dwelling

## 1.0 SUMMARY

This document has been prepared to demonstrate how the proposed dwelling at Ampleforth satisfies the criteria of Paragraph 79 of the National Planning Policy Framework.

The Framework was revised in July 2018 to implement reforms announced previously through the Housing White Paper, the planning for the right homes in the right places consultation and the draft National Planning Policy Framework consultation.

National policy pertaining to the development of isolated homes in the countryside was previously covered by Paragraph 55 of the NPPF; the revisions to the NPPF have resulted in Paragraph 55 becoming paragraph 79 – however the wording of the policy remains the same as that prior to publication of the revised NPPF.

Paragraph 79 of the NPPF states;

Planning policies and decisions should avoid the development of isolated homes in the countryside unless one or more of the following circumstances apply:

- a) there is an essential need for a rural worker, including those taking majority control of a farm business, to live permanently at or near their place of work in the countryside;
- b) the development would represent the optimal viable use of a heritage asset or would be appropriate enabling development to secure the future of heritage assets;
- c) the development would re-use redundant or disused buildings and enhance its immediate setting;
- d) the development would involve the subdivision of an existing residential dwelling; or
- e) the design is of exceptional quality, in that it:
  - is truly outstanding or innovative, reflecting the highest standards in architecture, and would help to raise standards of design more generally in rural areas; and
  - would significantly enhance its immediate setting, and be sensitive to the defining characteristics of the local area.

This Design and Access Statement, together with the other supporting surveys, assessments and reports submitted in support of this planning application demonstrate how the proposal satisfies the above criteria of Paragraph 79. This DAS should be read in conjunction with the Landscape Statement and the Planning Statement, which sets out in detail and with reference to case law how the proposed dwelling is considered to be truly outstanding or innovative.

The scheme has also given due regard to the provisions of Paragraph 131 of the NPPF which states;  
"In determining applications, great weight should be given to outstanding or innovative designs which promote high levels of sustainability, or help raise the standard of design more generally in an area, so long as they fit in with the overall form and layout of their surroundings."

The scheme, as this planning submission demonstrates, is both an outstanding and innovative design which promotes

high levels of sustainability, and helps raise the standard of design more generally both in the local area and beyond. The scheme is based on a detailed understanding of the site and its surroundings, thereby ensuring the scheme both complements and enhances local character and distinctiveness. Further details of how the scheme satisfies the criteria of Paragraph 79 and Paragraph 131 of the NPPF are detailed within this Design and Access Statement, the Planning Statement and the other surveys, assessments and reports submitted in support of the planning application.

Subheads below provides a summary of how the proposal satisfies the criteria of Paragraph 79, as well as Paragraph 131.

### Exceptional quality

The scheme is far from ordinary. It is far more than the development of a dwelling – each element of the scheme has been thoroughly critiqued and revised to accommodate comments from experts within the fields of design and sustainability. Extensive research of the site and its surroundings has been undertaken to understand the history and evolution of the site, and to identify sensitive receptors. The submitted scheme has given due regard to the characteristics of the site and the wider area. This scheme has been presented at two Design Review Panels whom concluded at the second review that the scheme "was developing into one of the best and most interesting Paragraph 55/79 schemes that the Panel has seen."

The scheme is unique in concept and tests contemporary limits of housing construction and design. The scheme is inspired by, and will make a modern contribution to, local cultural heritage and will raise the benchmark for new country houses and farmsteads. The project is exceptional in terms of the legacy it will create and significant, though sensitive, enhancement of the landscape setting.

### Truly Innovative

Innovation differs from invention in that innovation refers to the use of a better and, as a result, novel idea or method, whereas invention refers more directly to the creation of the idea or method itself. Innovation also differs from improvement in that innovation refers to the notion of doing something different rather than doing the same thing better.

With this in mind, the scheme is highly innovative in both its architectural expression, the way it enhances its immediate setting and the range of building technologies integrated into the concept. Indeed, the Design Review Panel confirmed that the scheme "as a whole represents an innovative reinvention of the farmstead typology."

The scheme incorporates a Building Management System to combine a variety of state-of-the-art technologies in heat storage and recovery, hybrid photovoltaic and

thermal energy collection, underground and water heat collection, passive thermal heating, in an integrated manner unique to a domestic dwelling in the UK. Further details of the scheme's sustainability and innovativeness can be found within the submitted Sustainability and Innovation Statement.

#### **Truly Outstanding**

This building will certainly stand out from the crowd by nature of the conspicuous appearance and how it fits itself sensitively into its site. The scheme celebrates local distinctiveness in its boldness of design and as a quiet, green, and special place for biodiversity, wildlife and people.

Indeed, the Design Review Panel stated that the scheme "is a very distinctive and unique proposal, many people won't have seen anything like this before [...] this is a very exciting proposal with the potential to be considered outstanding."

Further details of how the scheme can be considered to be a truly outstanding design are included within the Design and Access Statement and the Planning Statement.

#### **Raise standards of design in rural areas**

This building provides a visible piece of outstanding design. It will be noticed on the national stage and raise standards of design more generally. It provides an exemplar for experimental technologies for use in other buildings.

#### **Reflect the highest standards in architecture**

This design has significant theoretical and academic underpinning as outlined in this statement. It is an unusual organic form, expression of cutting edge design for the 21st century, both in its design and the methods used to design it.

#### **Sensitive to the defining characteristics of the local area**

The scheme is based upon a comprehensive understanding of the site, its historical evolution and local contextual factors. A detailed landscape appraisal has been undertaken which has informed the siting of the proposed dwelling, its height, massing, form and layout, as well as the proposed palette of materials.

The scheme acknowledges the site's location within the Howardian Hills AONB and it is considered would both conserve and enhance the natural beauty of the AONB, through landscape management and the introduction of a truly outstanding and innovative development, which will help raise the standards of design in rural areas both locally and nationally.

Further details of how the scheme responds to the defining characteristics of the local area can be found within the Landscape Statement and the Planning Statement.



Panorama of the Site from the Proposed Site Location

## 2.0 CONTENTS

		page
A Introduction : Paragraph 79	1.0 Summary : Paragraph 79 Criteria	3
	2.0 Contents	5
	3.0 Statement	7
	4.0 Project Brief	8
B The Site : Analysis : Design Strategy	1.0 The Site : Process and Choice	12
	2.0 Historical Background : Site : Design History	14
	3.0 Site Design Analysis	18
	4.0 The Design Strategy	20
C Design Development	1.0 Overview & Initial Concepts	27
	2.0 Design Review 1	30
	3.0 Design Review 2	33
	4.0 Scheme Design	41
D Conclusion	1.0 Meeting the Requirements of Paragraph 79	47
E Appendices	1.0 November 2017 Design Review Proposals	53
	2.0 November 2017 Design Review Feedback	70
	3.0 April 2018 Design Review Proposals	78
	4.0 May 2018 Design Review Feedback	116



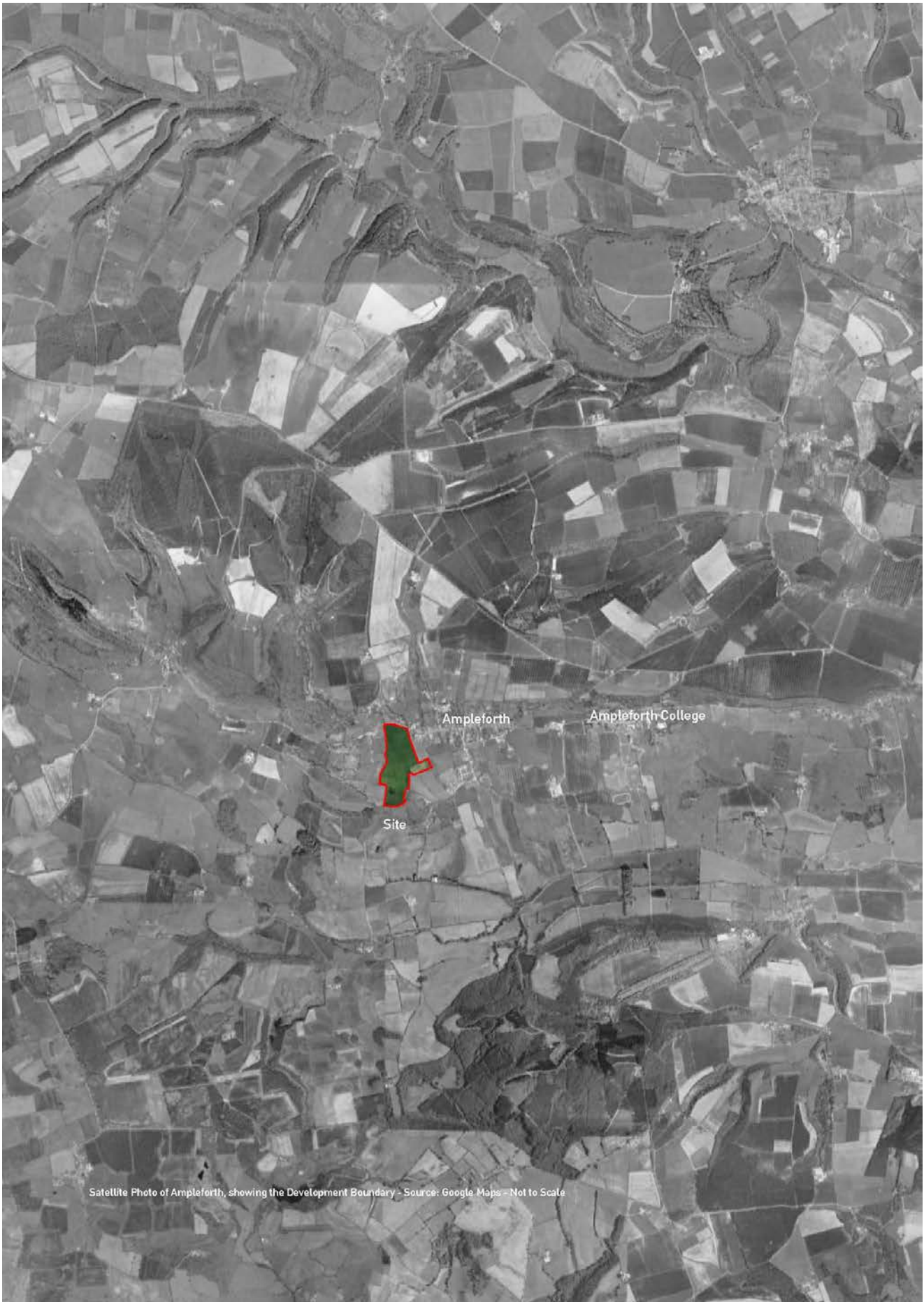

Satellite Photo of Ampleforth, showing the Development Boundary - Source: Google Maps - Not to Scale



## 3.0 STATEMENT

This statement justifies the design decisions taken in the development of an exceptional and innovative new dwelling at Ampleforth.

This document shows the design journey that has been undertaken from first visit to site, through production of the first iteration, pre-application liaison with stakeholders, and then through subsequent refinements to arrive at the current design.

The detailed information included in the document demonstrates that the design is both exceptional and innovative in terms of its cutting edge architecture and technology.

### 3.1 NPPF paragraph 79 Assessment Criteria

Fundamental to the design process for the new dwelling has been the need to develop a design that meets the requirements of paragraph 79 of the NPPF (National Planning Policy Framework), while at the same time ensuring that the new dwelling and the accompanying barn and stables balance the functional requirements of a family home with the aspirations for an innovative and exemplary low carbon farmstead set within an English rural context.

Paragraph 78-79 of the new National Planning Policy Framework document state:

"To promote sustainable development in rural areas, housing should be located where it will enhance or maintain the vitality of rural communities. Planning policies should identify opportunities for villages to grow and thrive, especially where this will support local services. Where there are groups of smaller settlements, development in one village may support services in a village nearby. Planning policies and decisions should avoid the development of isolated homes in the countryside unless one or more of the following circumstances apply..":

At point e) a special circumstance applies when the design is of exceptional quality, in that it:

- is truly outstanding or innovative, reflecting the highest standards in architecture, and would help to raise standards of design more generally in rural areas; and
- would significantly enhance its immediate setting, and be sensitive to the defining characteristics of the local area."

It is important to analyse, understand and define the criteria to which we believe Paragraph 79 alludes. For a building to be exceptional, it should form an exception and not be ordinary. This is evident within the designed scheme. Similarly, for a building to be innovative, it should display new methods and ideas, which does not necessarily mean unique. Again, this scheme evidently displays new ideas and new methods in the application of technology. For a building to be truly outstanding, it should be visible, remarkable or striking. This scheme displays all of these characteristics and views of the building within the wider landscape setting will be celebrated.

The scheme is intended to raise the standard of design more generally in rural areas. That means rural areas in general, not in North Yorkshire alone. In order to do this the exceptional quality of the scheme needs to receive local as well as national attention. It is our intention to publicise the exceptional quality of this scheme through the specialist press and wider media.

For a scheme to enhance significantly its immediate setting, it should in an appreciable way improve the value and quality of the immediate area in which it sits. The value of the site and the way in which the introduction of this scheme into that setting will conserve and enhance its setting.

This scheme needs to be sensitive to the defining characteristics of the local area and therefore consideration is brought, not just to the immediate setting, but also the wider context. The scale and materiality of the proposals need to reflect a sympathetic approach to the 'Genius Loci' of area. Further explanation is developed in this document and is again set out within the Landscape Statement.

The statement explains in detail how the requirements of paragraph 79 of the NPPF and the planning policy text relating to the development are met.

## 4.0 PROJECT BRIEF

### 4.1 Overview of the Brief

The delivery of a truly exceptional and innovative dwelling is reliant on the commitment of the future residents to create something of outstanding quality that meets the NPPF Paragraph 79 test and the realisation by them that their new home must make a genuine contribution to the qualities of the area in which it is sited and to the tradition of exceptional architecture at both a regional and national level.

Essential requirement of the brief was to achieve an intimate family home that interacts with the landscape, engage visually and physically with the land and would foster a stronger relationship with the pond, trees, hedgerows and the wider landscape. Initial brief is shown in more details below.

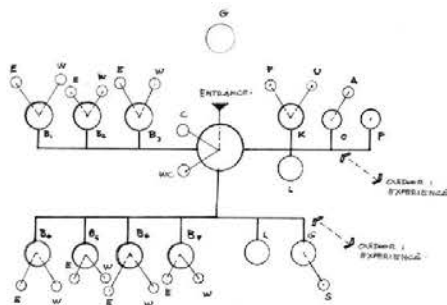

A : ARCHIVE	D : DINING
E : EN-SUITE BATHROOM	G : GARAGE
C : GARAGE	H : HALL
O : OFFICE	I : KITCHEN
F : ENTRY	J : LIVING
PL : PLANTROOM	K : PORCH
	L : PORCH
	M : PORCH
	N : PORCH
	O : PORCH
	P : PORCH
	Q : PORCH
	R : PORCH
	S : PORCH
	T : PORCH
	U : PORCH
	V : PORCH
	W : PORCH
	X : PORCH
	Y : PORCH
	Z : PORCH

### 4.2 The Client and the Land

The site is at a critical moment in its history. In fact, continued limited use and management will result in a degraded, overgrown landscape with deterioration of the existing features. Therefore there is an opportunity not only to restore this land, but also to bring it to new purpose and meaning, securing its future to the next generations.

The Client's grandparents were descendants of some of the original settlers in the village and the family have remained residents ever since. There is a strong family history in relation to the village of Ampleforth, showing the commitment in bringing continuity to the ownership of the land.



Panorama from the North West corner of the site

#### 4.3 The Essence of the Brief

##### General

- Organic principles to design and build an extraordinary house which is part of the landscape.
- Enhance the landscape, with the architectural and landscape proposals in holistic union.
- Preserve and enhance the existing pond.
- Reduce waste and minimise the environmental footprint.
- Utilise new technologies.
- Use Eco and natural materials.

##### Living area

- Open plan main living space – includes kitchen, dining and living room.
- Ability to command a view of the pond, as well as the approach to the house.
- Direct access to outdoor spaces through full height glazed access doors, outdoor space to include places to sit during the summer months.

##### Bedrooms

- 7 bedrooms, including master bedroom.
- All rooms to have double beds and en-suite bathrooms.
- Walk in dressing rooms.

##### Garage

- Enclosed parking provision for 4 cars.

##### Other

- Utility space off the kitchen area.
- Pantry space off the kitchen area.
- Gym situated at lower level, yet allowing visual communication with the outside.
- Small study area near the living area.
- Snug / cinema room at lower level.
- Guest toilet near entrance hall.
- Cloak room near entrance hall.
- Plenty of storage.

##### Ancillary Unit

- Games/entertainment space separated from the house
- Understated presence not in visual competition with the house.





SECTION B  
THE SITE : ANALYSIS : DESIGN STRATEGY

## 1.0 THE SITE : PROCESS

### 1.1 The Landscape Appraisal

The Landscape Appraisal, by the Landscape Agency, that accompanies this application, comprehensively captures the essence of the site, zooming in from its National Location, to the character of the landscape of North Yorkshire, to the site and its immediate surroundings, and its sense of place.

### 1.2 The Site: Choice

The position of the house within the wider landscape is proposed to be sited at the bottom of the land, to allow a strong physical and visual connection with the land itself.

If located at the north end of the site, the connection with the land to the south would purely allow the observation of distant views, rather than allowing a more harmonious and tangible interaction with the landscape in proximity.

Developing the dwelling close to Knoll Hill would result in a home which is highly visible from key viewpoints, potentially dominating and detracting from the landscape setting. Similarly, a house which is perched, looking down on to the village, was considered too imposing and possibly even arrogant in this sensitive context.

For these reasons it proposed that the house should gently nestle within the site contours to the south west corner of the land.

Following diagram shows location options of dwelling, barn and stables, following the first design review.



View of the selected house location from the pond looking West

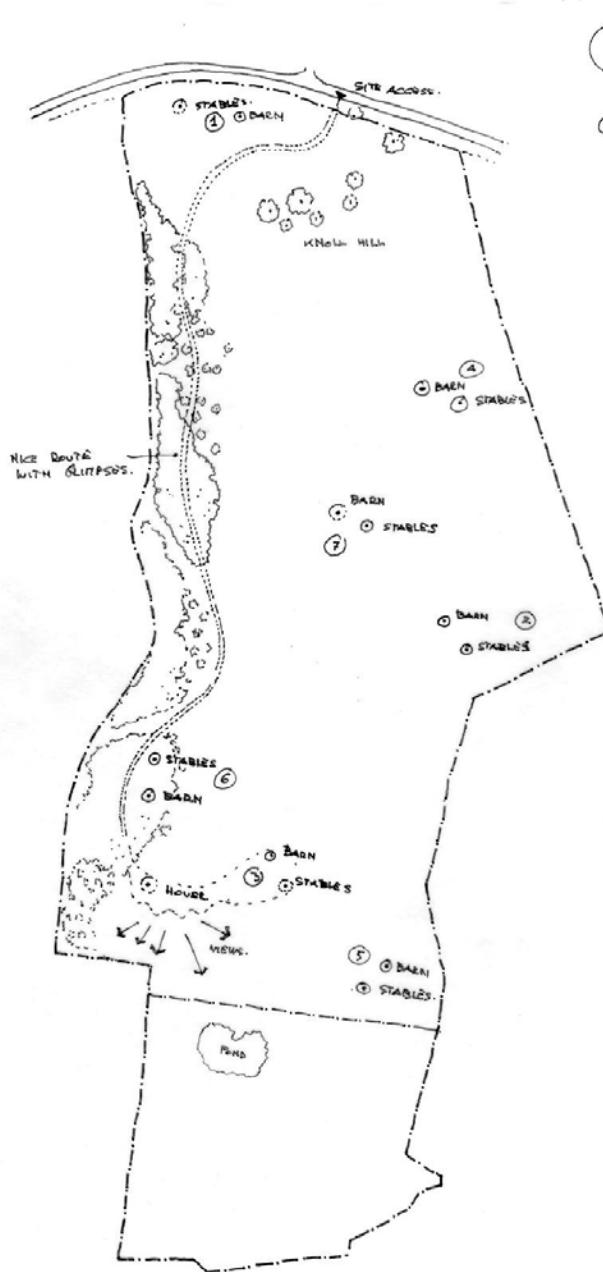

- ① - STABLES TOO CLOSE TO ROAD.
  - NEAR FOOT ROAD.
  - POSSIBLE WINDS?
  - TOO DETACHED FROM HOUSE (SECURITY ETC...).
  - BARN TOO DISTANT.
- ② - GROSS SITING.
  - TOO DISTANT FROM HOUSE.
  - REQUIRING ADDITIONAL ROAD.
  - PROBABLY TOO WINDY.
  - VISUAL IMPACT.
- ③ - IN HOUSE PROXIMITY.
  - IDEAL LOCATION.
  - VISUAL IMPACT - TO CONSIDER.
- ④ - TOO DISTANT.
  - VISUAL IMPACT.
  - PROBABLY TOO WINDY?
  - SIDE ROAD?
- ⑤ - WELL NESTLED.
  - REDUCED VISUAL IMPACT.
  - ADDITIONAL ROAD EXTENDS.
- ⑥ - NOT NICE SECURITY APPROACH.
- ⑦ - VISUAL IMPACT.
  - TOO DISTANT.

## 2.0 HISTORICAL BACKGROUND

### 2.1 The History of the Land

The land has not changed significantly since the 19th Century. The Design Team has analysed Historical Maps sourced from the National Library of Scotland, showing that the land was previously subdivided in smaller patterns, in tune with the neighbours' lands. The current land, as visible from distant views, seems to be dominant for its emptiness and slightly imposing.

Following the first Design Review, it has been agreed that bringing these patterns back, although not copying their historical geometrical arrangement, would help the site to reinstate a dialogue with the wider landscape context.



Comparison between historical map (1888-1913) and current satellite picture.  
Source: National Library of Scotland/Bing



Comparison between historical map (1937-1961) and current satellite picture.  
Source: National Library of Scotland/Bing





Satellite Photo of the Site Showing the Development Boundary - Source: Bing Maps - Not to Scale

## 2.0 HISTORICAL BACKGROUND

### 2.2 The History of the Design

The scheme in this application is the result of a long period of observation, analysis, creativity and architectural rigour.

Over an extended period of time, Kevin Brown and Luca Biselli have visited the site on many occasions, and immersed themselves in the experience of the land, its sinuous forms and contours, the pond and capturing the visible. The proposed scheme is the result of a long deliberation aiming at a strong relationship between architecture, landscape and agricultural activities.

The design team sought pre-application advice from Ryedale District Council in August 2017 in order to seek guidance on relevant Development Plan Policies. The response highlighted policies at National Level as well as Local Plan Strategy adopted 2013. The accompanying Planning Statement addresses how the scheme has met the requirements set out in the pre-application response.

In addition to planning policy guidance, the pre-application response indicated that, in terms of design, the Design Team would seek for Yorkshire Design Review Panel to review the proposals. Over the course of the design development the design team sought two separate reviews with IntegratePlus (Yorkshire Design Review Panel) in November 2017 [see appendix 02] and May 2018 [see appendix 04]. On both occasions the response to advice from the Design Review Panel has been considered and helped to develop the proposals. A description of the response and the efforts to address the comments are found in Section C of the Design Development.



View from top of Knoll Hill Looking South

### 3.0 SITE DESIGN ANALYSIS

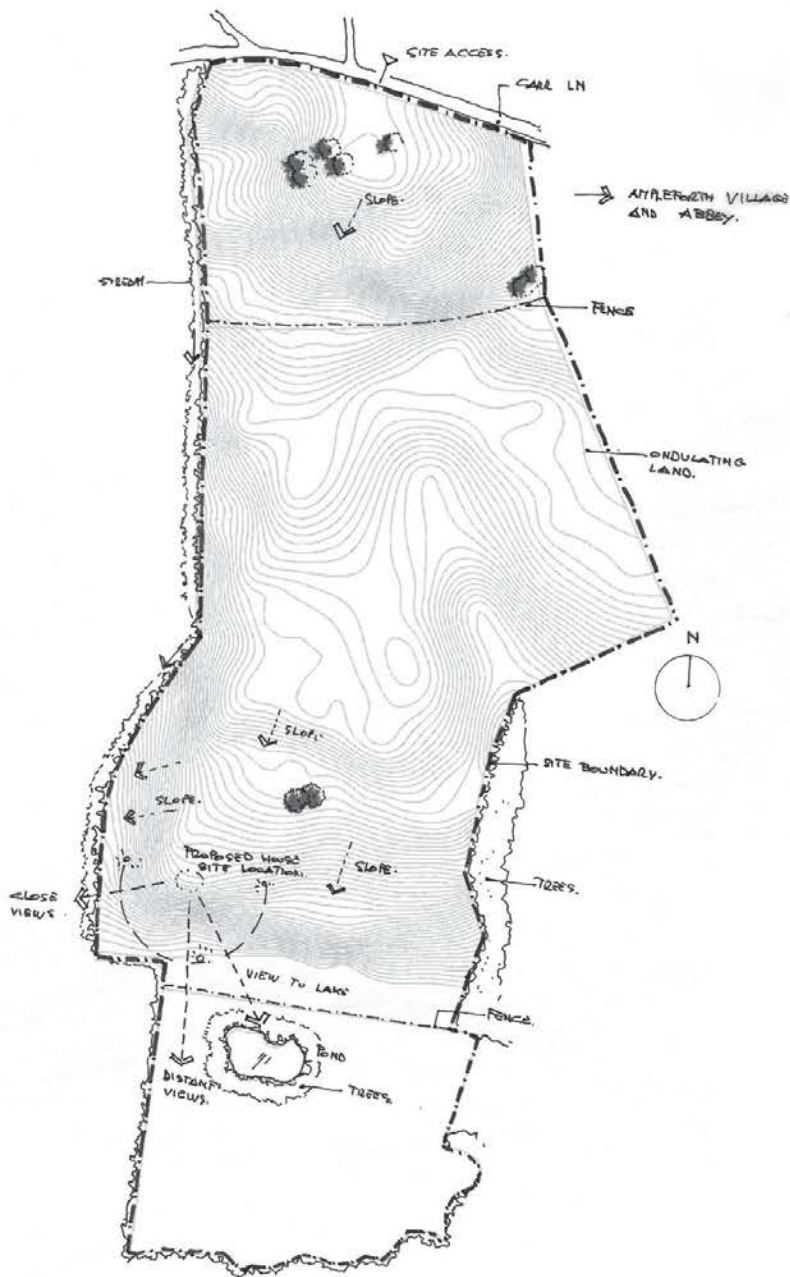

## General

The principles behind the proposed development in the wider site are explained in the Landscape Statement document accompanying the application.

The strongest themes of the landscape proposals relevant to the architecture can be summarised as follows:

- House nestled down the South West bottom end corner of the land, in tune with the site contours.
- Barn and Stables nestled within the contours.
- Low key access road, providing sense of journey to the house within the proposed plants.
- Orchards to suit the contours.
- Pond restored and becoming an active part of the ecosystem.

## 4.0 DESIGN STRATEGY

### 4.1 Contextually Derived Solutions

The design team approached the design in a manner where decisions could be informed through observations of the site context. This could be an aspect of the wider context, site specific or a historical aspect.

The historical apple production located at the Ampleforth Abbey has strongly inspired the general architectural concept, as well as the general site development as a site supporting apples for cider production.

The idea of a "germinating house", which grows from the ground up, blending visually to the setting with roots emerging from the ground and covered with climbing plants, borrows inspiration from sprouts, seeds and how they grow and physically relate to the ground.

### 4.2 Organic Architecture

A term first used by Frank Lloyd Wright, Organic Architecture is described as a harmony between human habitation and the natural world. Key to this harmony is how the intervention is sympathetic and well integrated with its site, that buildings, furnishings, and surroundings become part of a unified, interrelated composition. The approach is centred on programming space from the inside out, rather than defining a shell and forcing a spatial programme to work within. The approach of the design of the Falling Water (Kaufmann House), by Frank Lloyd Wright, is a well known example of Organic Architecture.

The design of the dwelling at Ampleforth follows the Organic Architecture principles:

- The site should be enhanced by the building. The building devises its form partially from the nature of the site. Sometime this is done by similarity, sometimes by contrast.
- Materials should be used simply in a way that enhances their innate character.
- A building should convey a sense of shelter, refuge or protection.
- Interior space is not packed in boxes called rooms, rather the space should flow freely from interior area to interior area.
- The human body should be the measure of a building and its furnishings.
- Mechanical systems and finishing are integral part of the building, not added on. Furniture should be built in as much as possible.
- Forms which reflect forms found in nature. These concepts underlie the architectural philosophy of this scheme at Ampleforth. These forms, whilst enshrined in an architectural philosophy, have a practical application in the patterns of light and shade that they create. These 'free forms' are applicable to the use of natural materials, which can be sculpted with timber used to clad the external envelope of this building.
- From the seeds growth comes the idea of movement when the ground surface is disturbed. The house is formed by five interconnecting metaphors of leaves, which not only borrow from the ancient idea of plants as primary forms of shelters, but also actively interact with the environment, collecting water to be recycled within the dwelling.

### 4.3 Curvilinear Design

As mentioned in 4.1 and 4.2 this project builds upon an architectural philosophy which is encapsulated in contextually derived solutions, alongside organic principles. A strong and philosophical based architectural approach produces uncompromising buildings which enshrine the principles set out in Paragraph 79. The "highest standards in architecture" are achieved by buildings which carry through those principles into every detail of the building. Geometrical proportions are then used in an uncompromising manner to set the scale, length, proportion and controlling dimensions of each part.

The resultant forms are curvilinear in plan and, partially, in elevation, providing an extraordinary internal space. "Circular living provides a balance looking inward and outward, looking out at the natural environment and surroundings but then coming in again to the self and the hearth" (David Raitt, Yurts Living in the Round).

It is our belief that curved forms, as living spaces, provide a better sense of well-being. The mystical properties of this philosophy are enshrined in the Chinese philosophy of Feng Shui and such forms are common in ancient cultures with roundhouses and yurts. We seek to build upon the mystical relationship between man and nature with our buildings, so that nature is given expression in physical and harmonious forms. We believe through this architectural approach that we create the "highest standards in architecture".

### 4.4 Exceptional in its Architectural Approach

Roger H. Clark and Michael Pause in their book, 'Precedents in Architecture: Analytic Diagrams, Formative Ideas, and Parts' (2005) state: "It is rare to find a building configuration which embodies a single formal theme in absolute purity. More normal is a variety of patterns layered upon one another - the consequence of which is the potential for the richness that can evolve from multiple interpretations."

With regard to NPPF Paragraph 79, the team have sought to address the notion of 'exceptional' with the use of multiple themes. The term 'exceptional' is, therefore, understood as being held in the sense of integration; whether the themes integrate to show a well-considered design approach which is 'above the norm'.

## 4.0 DESIGN STRATEGY

### 4.5 Sustainable and Technical Innovation

Sustainable design principles have been applied to deliver a low impact design that is appropriate to both the demands and setting of the building on the site. A holistic approach has been taken to minimise the reliance on external sources of energy, both during construction and throughout the lifetime of the project and focuses on four of the key areas that define sustainability.

These are:

- Energy and Carbon Dioxide Emissions
- Water
- Waste
- Pollution

To deliver energy savings effectively, the site-wide strategy has been based on the application of an energy hierarchy of mean, lean and green.

This is summarised in the Sustainability Report by the Ethical Partnership, which forms part of this submission.

The focus has been towards an innovative design, whilst not detracting from the natural surroundings of the site.

Sustainable systems proposed in this scheme include: rain water harvesting, passive solar gains, heat exchange and storage and electricity generation.

### 4.6 Climate Change and Access

#### Minimised energy use, and maximised use of renewables

The design team have not chosen to adhere to one particular design standard (e.g. Passivhaus), but to adopt a best practice from environmental standards wherever possible in the pursuit of holistic solutions to the creation of a sustainable and innovative development. The intention is to utilise renewable energy systems capable of reducing and offsetting all carbon emissions from the site during operation. Space heating is via ground/water sourced heat pumps, while the proposed photovoltaic - thermal allocation is capable of providing electricity for use on-site, and for exporting to the national grid when generation exceeds demand.

The total thermal requirement for the new dwelling at Ampleforth has been modelled. (see Ethical Partnership Report) The report sets out the market's ability to provide an approach to meet the building's energy demands and to provide a means for inter-seasonal energy storage.

A review of the suitability of the innovative Trombe walling has been undertaken to ascertain the potential energy contribution to the building's overall energy requirements. This model provides an understanding of the potential level of contribution—subject to material selection and wall thickness, glass type and opacity.

#### Sustainable travel/transport options during construction and operation

##### A building which will adapt to future climate change

The building has been designed to include a component of exposed thermal mass. Other climate change risks such as flooding and soil instability are not considered to be significant for this development.

#### Access

Access to the site from Carr Lane is left unchanged. Proposed main access route to the dwelling and to farmstead will be created to the West of the site, to minimise impact on key views to the Knoll Hill.

Maintaining Knoll Hill mostly unchanged within the wider landscape setting has been key priority. For more details refer to Landscape Agency Appraisal Report.



## 4.0 DESIGN STRATEGY

### 4.7 Environmental Resources Improved Biodiversity

The landscape design has been informed by a comprehensive Landscape Appraisal, a Landscape Visual Impact Assessment, a Preliminary Ecological Appraisal, Arboricultural Survey and Impact Assessment; all of which have been submitted in support of the planning application.

The landscape proposals will establish a managed and diverse regime to support existing habitats/ species. The proposals also incorporate the opportunities identified by the ecologists to improve species habitats into both the design and long-term management strategy.

The scheme will therefore conserve and enhance the ecological value of the site.

### 4.8 Reduced Water Use and Improved Local Quality Water

The dwelling will incorporate a rainwater harvesting system to collect rainwater to be used for non-potable applications, for example WC flushing, washing machines and vehicle washing. A number of water-efficient appliances and fittings will be utilised, in order to reduce consumption within the dwelling.

An initial desktop survey has been undertaken and a septic tank/ package sewage treatment plant draining to a soakaway is proposed as a suitable arrangement for foul water management

### 4.9 Risk of Flooding

A Flood Risk Assessment has been undertaken and is submitted in support of the planning application. The FRA confirms that the proposed development could proceed at the site without being subject to significant flood risk. Moreover, the development will not increase flood risk to the wider catchment area.

### 4.10 Sustainable resource use during construction

The materials to be employed in the construction of the dwelling will be selected according to the extent which they contribute to health and wellbeing of occupants, include content from renewable and recycled sources, and are of local provenance.

The construction is based on lean methods, utilising materials from renewable sources, which are available or produced as close to the site as possible. Wherever possible materials that incorporate a proportion of post-consumer recycled content will be used. This will allow the construction to stimulate the production of new construction materials and to minimise the carbon footprint of the construction. Further details can be found within the submitted Sustainability and Innovation Statement.

### 4.11 Reduced waste production during operation

It is proposed to create an orchard on-site to grow apples to supply the mill. The applicants also intend to produce cider themselves from the apples grown on-site, which they will sell in three local pubs which they own and manage. The establishment of the orchard is considered to have a positive environmental impact. There is also potential to use manure from animals on the site as fertiliser, and for the rainwater harvesting system to provide irrigation.

The generation of the heat and power demands for the dwelling will primarily be met using on-site renewable sources of energy; thereby ensuring the dwelling is not reliant on non-renewable sources.

### 4.12 Social Sustainability and Economy

#### A development which benefits the immediate and wider community

Given the history of apple growing in the area, it is considered that the proposals for an orchard are appropriate and reflect the economic and social character of the locality. The applicant will look to supply the mill with apples grown in the proposed orchard. The applicant will also look to produce cider themselves and sell it in three pubs which they own and manage. The three pubs are The White Swan and the White Horse in Ampleforth and the Fairfax Arms in Gilling East (The first Design Review was held here).

#### Increased provision of sustainable local employment opportunities

The opportunities for maintenance of the woodlands and infrastructure are important. The clients are committed to the involvement of the community and the opportunity for employment and local companies to be involved.

## 4.0 DESIGN STRATEGY

### 4.14 Lifetime Homes Statement

The Lifetime Homes Standard was established in the mid-1990s to incorporate a set of principles that should be implicit in good housing design. Good design, in this context, is considered to be design that maximizes utility, independence and quality of life, while not compromising other design issues such as aesthetics or cost effectiveness.

The Lifetime Homes Standard seeks to enable 'general needs' housing to provide, either from the outset or through simple and cost-effective adaptation, design solutions that meet the existing and changing needs of diverse households. This offers the occupants more choice over where they live and which visitors they can accommodate for any given time scale. It is therefore an expression of Inclusive Design.

Housing that is designed to the Lifetime Homes Standard will be convenient for most occupants, including some (but not all) wheelchair users and disabled visitors, without the necessity for substantial alterations.

A Lifetime Home will meet the requirements of a wide range of households, including families with pushchairs as well as some wheelchair users. The additional functionality and accessibility it provides is also helpful to everyone in ordinary daily life, for example when carrying large and bulky items. Lifetime Homes are not, however, a substitute for purpose-designed wheelchair standard housing.

In the context of this house, the building is designed towards the implementation of the lifetime homes standard in future years. The building is a timber construction and the frame allows future adaptability including the insertion of a platform lift for access between floors.

Circulation spaces are generous and provide plenty of scope for manoeuvring. In addition, the external doors are designed to have level access without threshold.

There is scope within a building of this nature for future adaptability. Similarly, there is scope in future to adapt bathrooms and serviced areas as well as components such as windows and doors to future needs. New adaptable products are constantly coming onto the market and the decision has been made to provide a house for now and not to second-guess what may become available in future years.

### 4.15 Light Pollution

The external appearance of the building at night has been considered as part of the design process. In addition, the lighting within the landscape which leads up to the building has been considered. It is the intention to minimise any overspill lighting to reduce light pollution and to use fittings which will light the routes at a low level only.

The illustrations that have been provided do not show any internal blinds, curtains or shutters, however the main living spaces will be curtained or obscured with blinds at night.



SECTION C  
DESIGN DEVELOPMENT

## 1.0 OVERVIEW & INITIAL CONCEPTS

### 1.1 Overview

The proposals are not only the result of a collaborative process between the Client and design team, but also a collaboration with input by leading professional peers within the built environment context. The role of the Yorkshire Design Review Panel (Integrate Plus) as an independent body in reviewing the proposals, has been considerable. Over the course of the design development, the design team sought two separate reviews with IntegratePlus in November 2017 and a subsequent review in May 2018. A copy of the Architectural Design Presentations are appended in Appendix 01 & 03. A copy of the Panel's written response are appended in appendix 02 & 04.

# 1.0 OVERVIEW & INITIAL CONCEPTS

## 1.2 Initial Concepts

The following sketches show a selection of key ideas which supported the first iteration of the proposals that preceded the first independent design review. After the site analysis, where several house locations have been explored, it was agreed that the best location would be at the bottom of the site, where the dwelling would be in a better contact with the pond, the landscape in proximity, yet allowing visual contact with distant views.

Initial conceptual ideas supporting the design development were based on seed growth and germination, borrowing the inspiration from the local production of apples for cider at Ampleforth. These imaginary seeds, creating movement and disturbance to the earth, while growing underground, became a physical design presence in the form of light wells, bringing light to the deeper rooms of the lower level.

Given the brief, requesting 7 bedrooms, it has been decided to split the building in two stories, with the lower level partially underground.

The movement created by the seeds has inspired a curvilinear form, which has become the initial key feature of the house form.

Additional inspiration from the seeds growth has further suggested a "germinating house" with roots covered with climbing plants, becoming the structural support of the upper level floor edge and elliptical roofs, metaphor of leaves, covered in grass and integrated to hoppers for water recycling.

Effectively, the building is a metaphor of the different stages of the seed growth, where every component has a function and contributes holistically to the creation of a living house. Hence why the term "germinating house" is being used in this report.

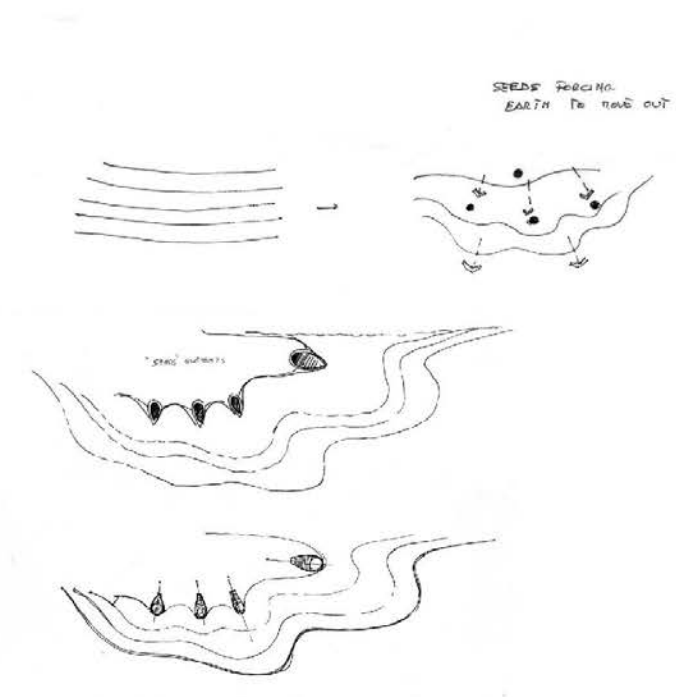

Initial Concept Sketches showing seeds disturbing the ground

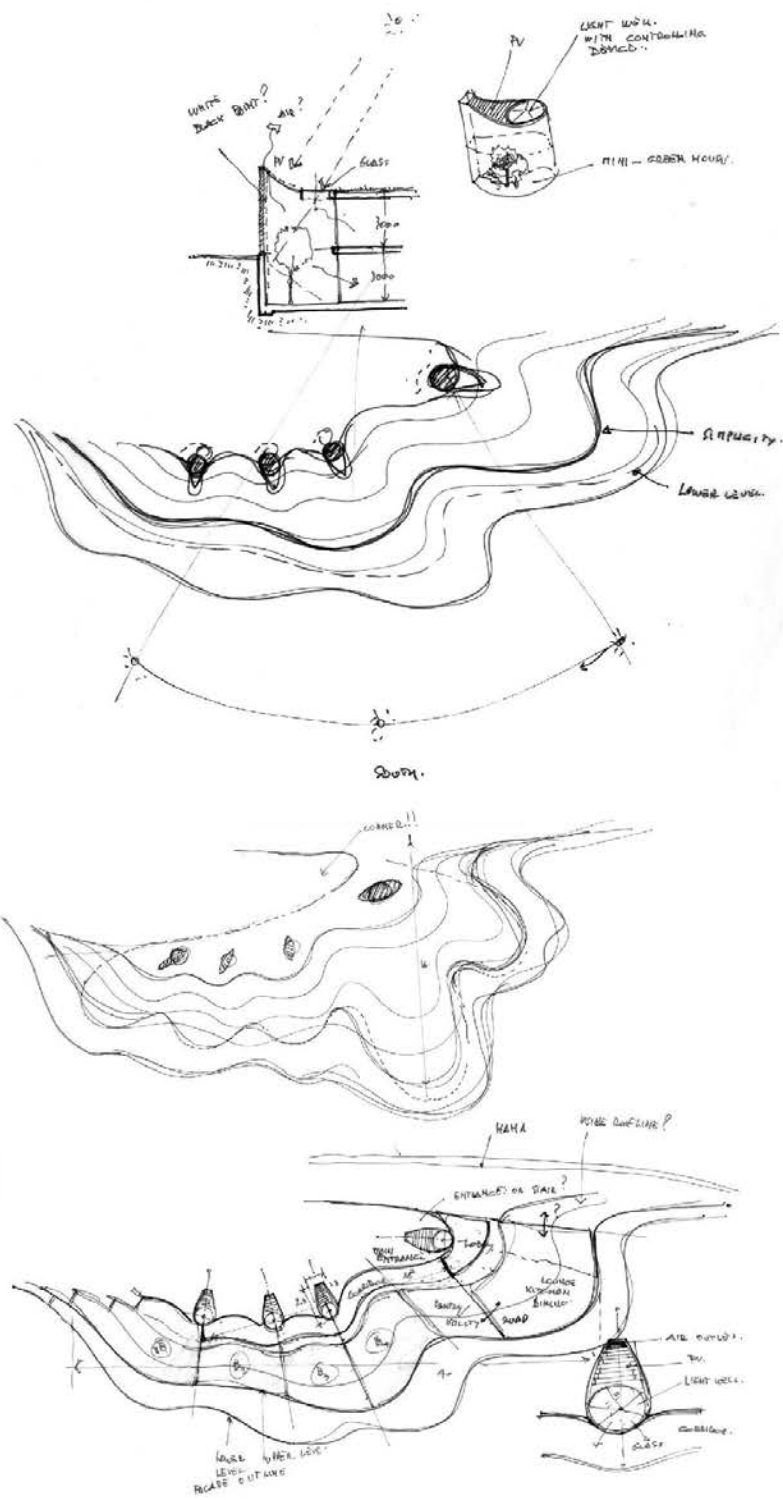

Development of initial concepts into the First Set of Proposals

## 2.0 DESIGN REVIEW 1

### 2.1 Presentation

A copy of the November 2017 full Architectural Design Presentation is appended in Appendix 01. The presentation included an evolution of the general conceptual idea of a "germinating house". Concept sketches show the development of plans based on the metaphor of seeds disturbing the ground while growing, becoming sprouts.

The "seeds" have become an integral part of the design in the form of light wells, bringing light to the lower level, which is partially underground.

Elliptical leaves cover the main spaces at upper level. Curvilinear forms, light wells and roof leaves can be seen working together in harmony.

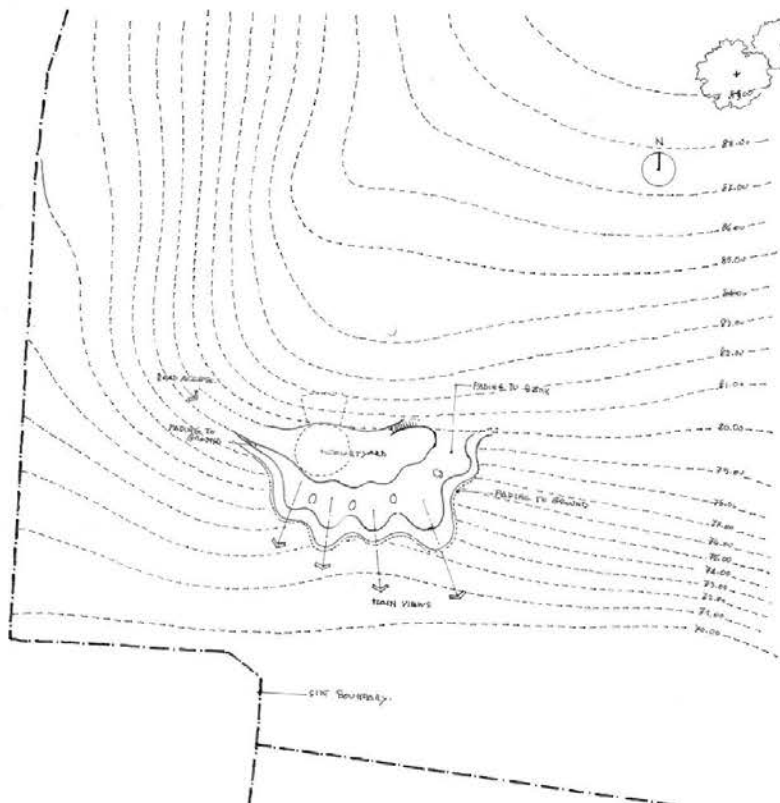

Copy of Sketch showing House Location in relation to the pond, Presented in the November 2017 Design Review Presentation



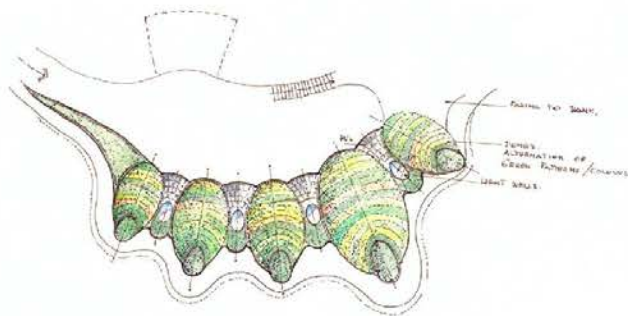
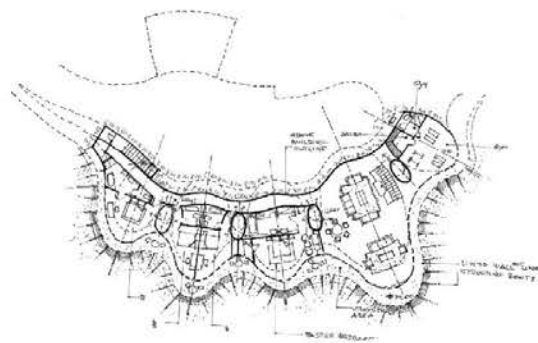
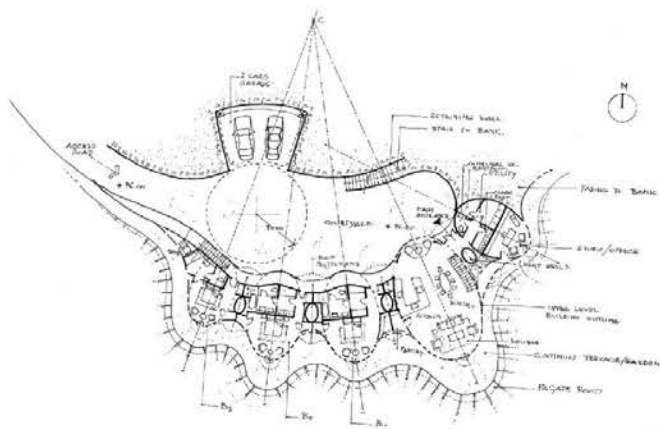

Copy of Proposed Floor Plans Presented in the November 2017 Design Review Presentation

## 2.0 DESIGN REVIEW 1

### 2.2 Feedback

A copy of the November 2017 Design Review Feedback letter is appended in Appendix 02. The panels response was positive, welcoming the 'germinating house' concept and thought that this could be potentially developed.

A summary of the main issues the Panel asked to be addressed included:

1. Articulating and justifying the rationale behind the selection of the site for the dwelling.
2. Communicating the long-term strategy for the management of the entire land holding and its integration into the wider landscape.
3. Defining the domestic curtilage and its relationship with the wider site.
4. Studying a road access which would suit the site contours and would provide a journey to the house.
5. Studying a more interesting local landscape, perhaps even with economical benefits.
6. Investigating a possible polycultural use of the site, maybe restoring the smaller fields patterns, not necessarily modelled on previous historical layout.
7. Reconnecting the pond to the land was welcomed, but question was raised on how the pond would relate and interact with the marshland, the house and the pasture land in different directions.
8. Focus on a comprehensive sustainable strategy.
9. Underlining the family history to the village of Ampleforth, developing the scheme around this important connection.
10. Showing how the building nestles into the hillside and its contours.

## 3.0 DESIGN REVIEW 2

### 3.1 Presentation

A copy of the April 2018 Architectural Design Presentation is appended in Appendix 03. The presentation included an evolution of the proposals, demonstrating how the proposed dwelling nestles in the hillside, refinement of the plans, the addition of an external pavillion and the integration of a barn and stables.

The barn would be needed to support the production of apples growing in the proposed orchards. This production will help the local production of cider at Ampleforth, as well as helping local apples supply.

The Landscape Appraisal shows in great details the wider context landscape design development, following the Design Review Panel comments.

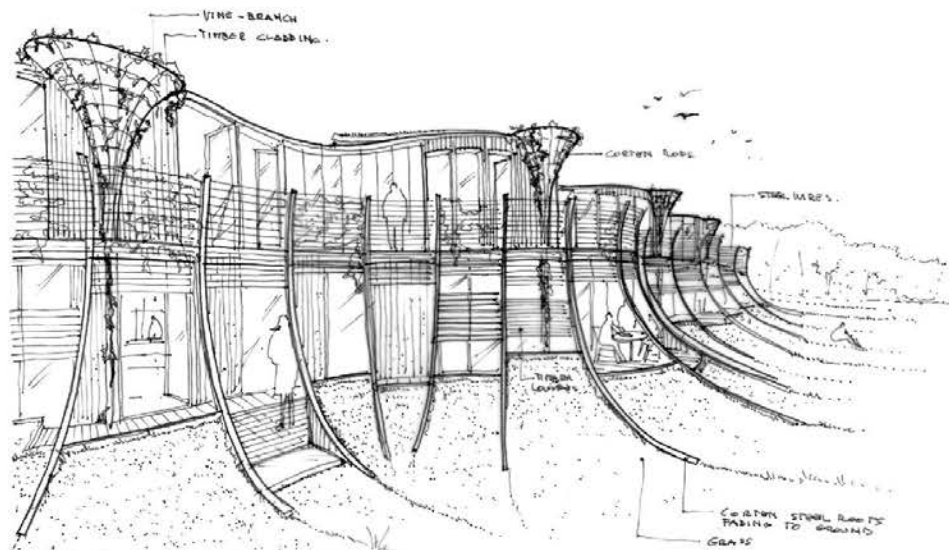

Copy of Sketch Perspectives Presented in the April 2018 Design Review Presentation

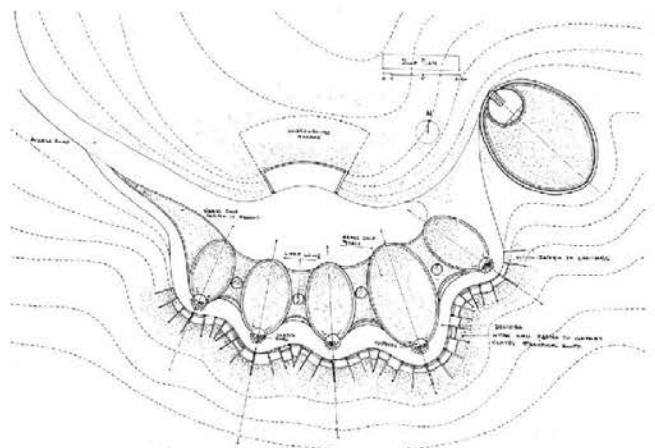
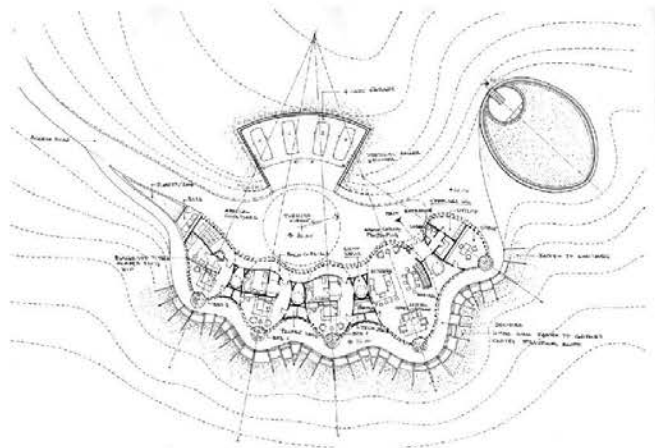
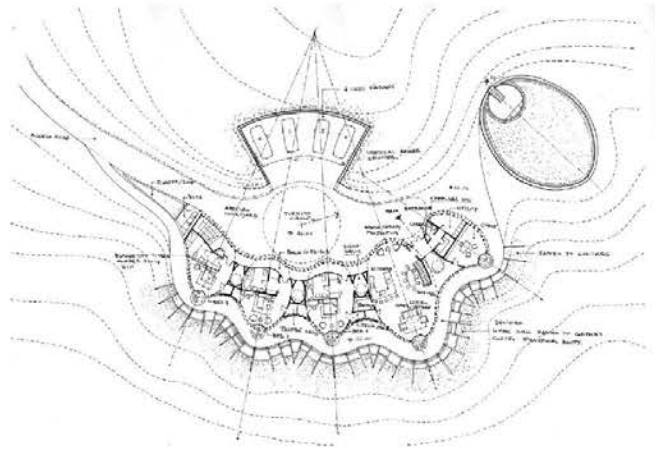

Copy of Proposed Floor Plans Presented in the April 2018 Design Review Presentation

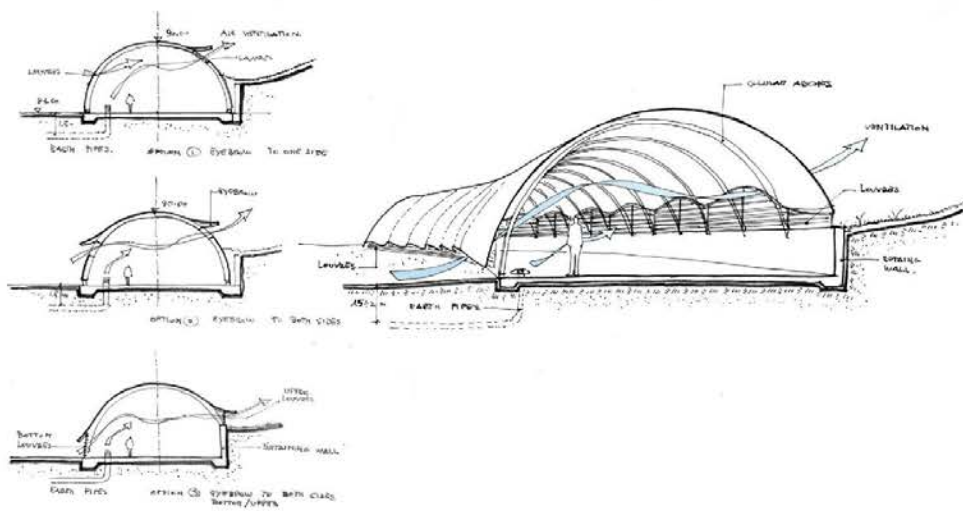
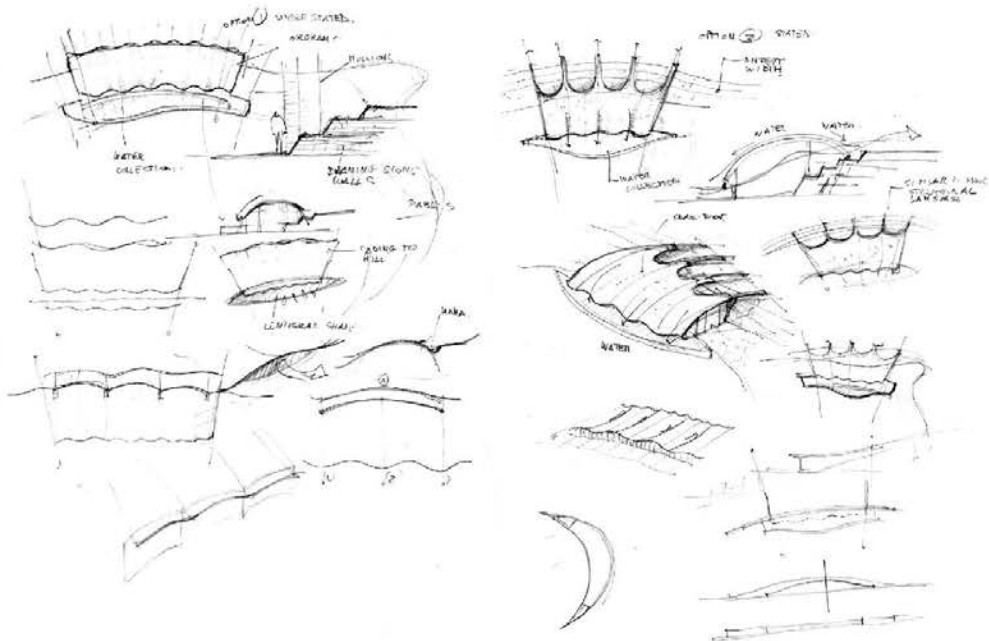

Selection of Pages from the April 2018 Design Review Presentation

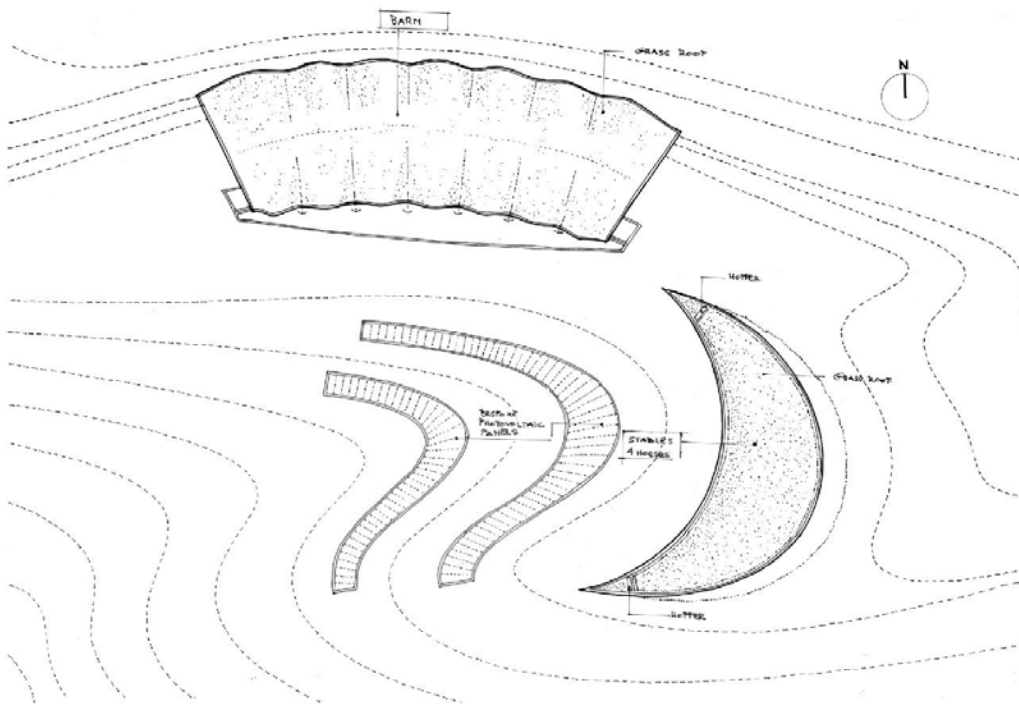
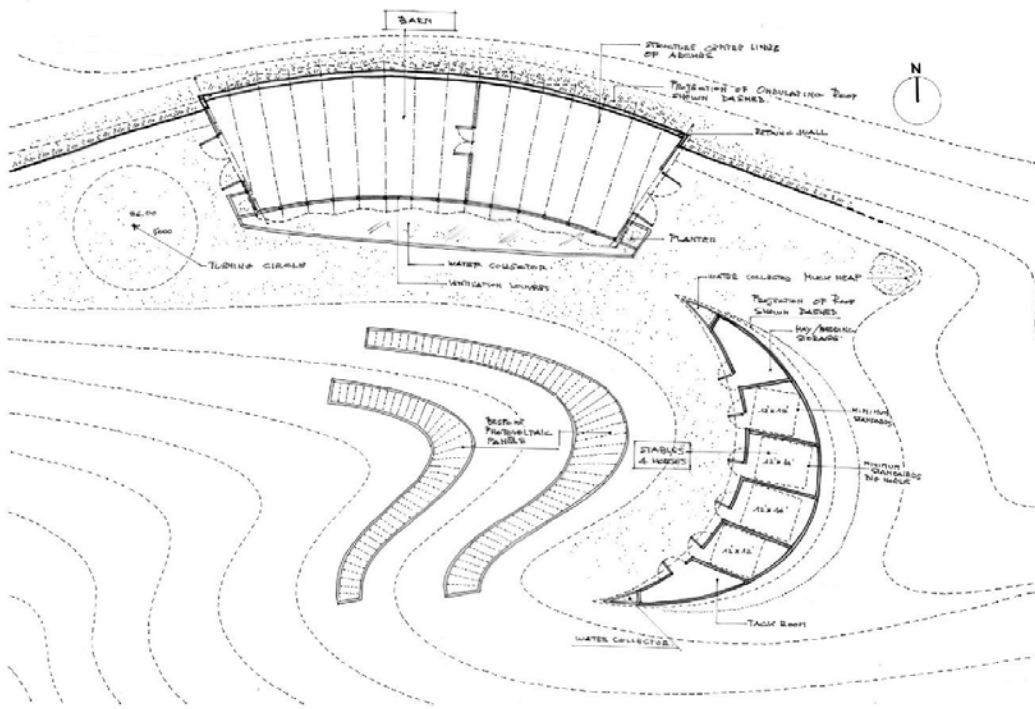

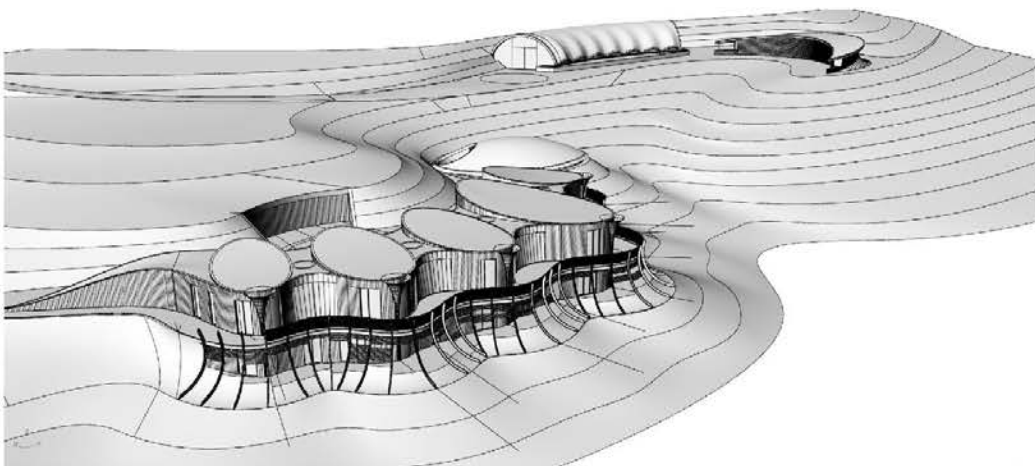
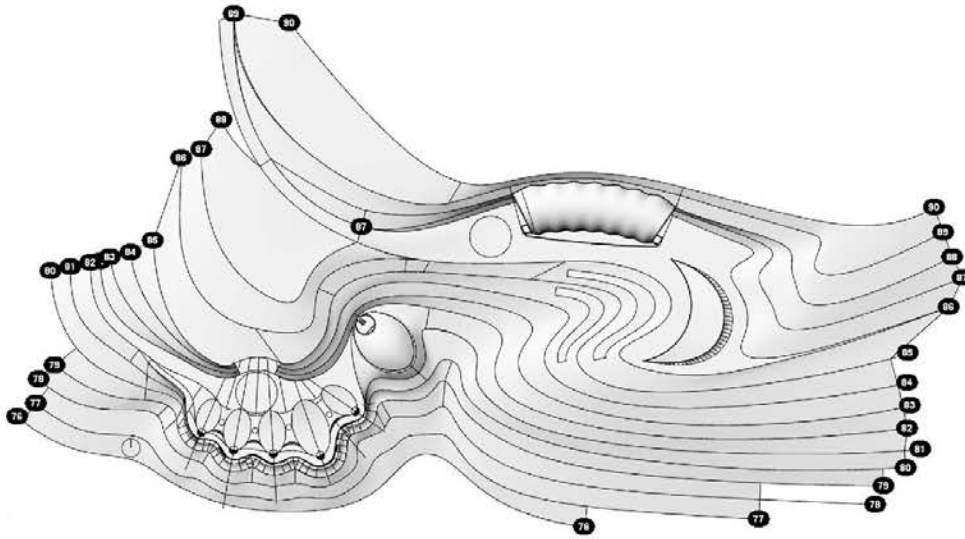

Copy of Computer Model Screenshots Presented in the April 2018 Design Review Presentation

## 3.0 DESIGN REVIEW 2

### 3.2 Feedback

A copy of the May 2018 Design Review Feedback letter is appended in Appendix 04. The Panels welcomed the proposals as "developing into one of the best and most interesting Paragraph 55 (now P79) schemes that the Panel has seen".

A summary of the main issues the panel asked to be addressed included:

1. Regarding barn and stables, although the Panel stated that they were individually well designed, it was noted some tension and conflict between the organic forms of the house and the more geometric barn and stable.
2. Further consideration towards the cloyster transition at lower level and its relationship to the organic form of the building, suggested the possibility of having it removed.
3. More work to be done on the elliptical roof and their form.
4. Creation of a physical model to better understand house, barn and stables in their context.
5. Refining the transitional area of land between the house, barn and stables, to give this space some more clarity and identity, which presently displays some ambiguity about whether it is garden, farmyard or cultivated area.



## 3.0 DESIGN REVIEW 2

### 3.3 Design Response

The issues raised in the May 2018 Design Review were considered over a further period of 3 months. The design development addressed the issues in the following ways:

#### Barn and Stables.

The response to better integrate barn and stables geometry within the overall architectural composition, has lead the design team to effectively re-think this typology. The form of the buildings has been conceived to take advantage of natural ventilation, by creating lower and upper "gills". While in traditional barns and stables the ventilation is often a retrofit solution, the case of Ampleforth shows a harmonic integration between form and function, which can indeed be called innovation in this typology.

Additionally, water troughs collect water from the green roofs, providing, once filtered, drinking water for horses and for the other water site needs.

#### Edge of building and "roots"

Following the comments from the Design Review Panel, it has been decided to omit the cloyster, pushing the lower floor edge towards the structural roots. This, in turn, has allowed the possibility of creating areas of planters and solar collectors, which would be horizontal, preventing any vertical glazed panel surface to be visible, apart from the windows apertures.

#### The leaves

Roofs and hoppers have been integrated in a unique form, never seen before, which acts as an integrated water harvesting device, contributing to the overall water collection strategy.

#### Climbing plants

Climbing plants will grow at terrace level, up to the roof fascia from the hoppers rods and through the balustrade mesh, via carefully designed planters. The landscape will also blend to the house in the space between the structural roots, partially covered with climbing plants and grass.

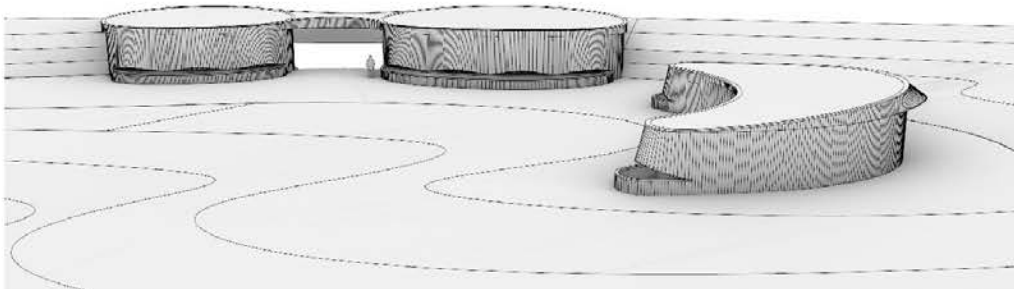

Computer model showing Barn and Stables

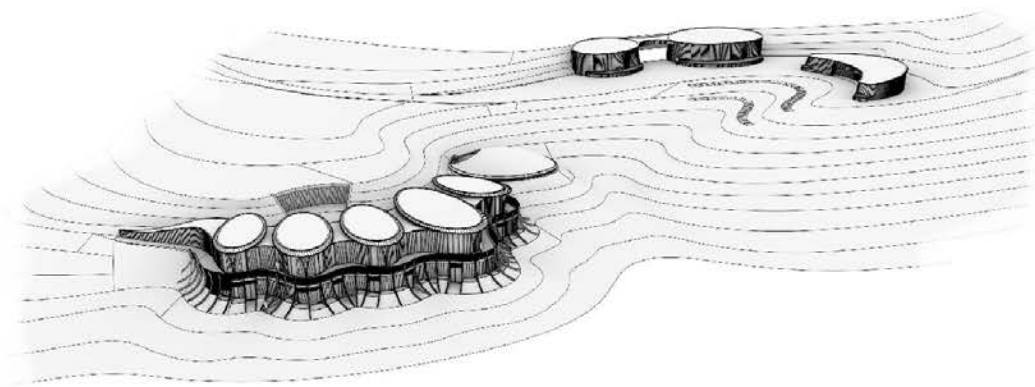
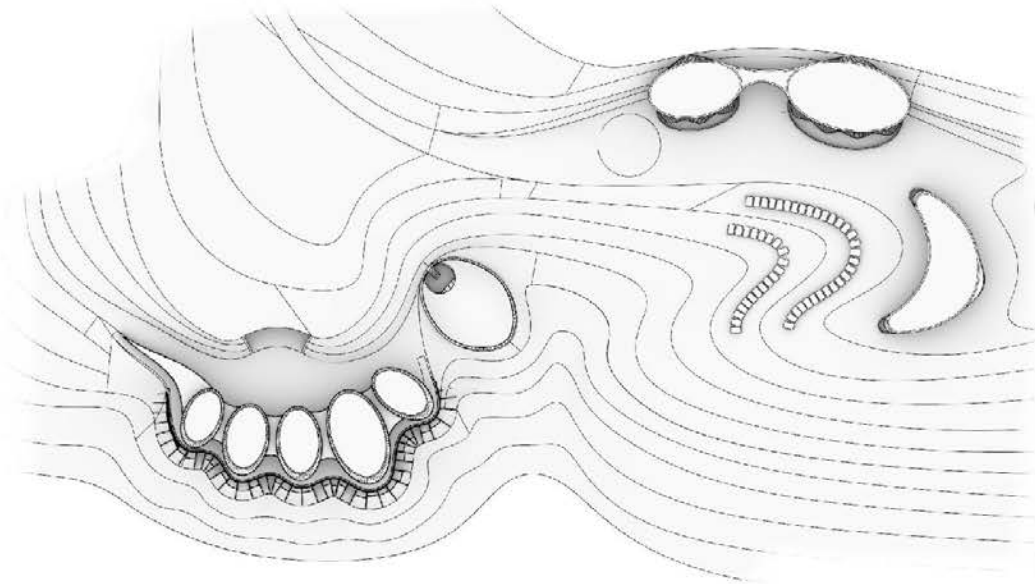

Computer model screenshots showing the overall harmonic composition

## 4.0 SCHEME DESIGN

### 4.1 Principles for Design

The proposals for this new house are a union between architecture and landscape observed in a modern contemporary approach to the development of the English Country House. The relationship between the landscape and the building is a key component of this scheme, integrating the new building with its wider landscape setting.

Over the past centuries, progressive architects have used 'the house' as a crucible for invention, a place to test novel concepts, forms and materials. This building builds on that tradition as seen in such iconic structures as Le Corbusier's Villa Savoye and Frank Lloyd Wright's Falling Water. A key component found in iconic examples is the role of context; where they are sited and how the architecture reacts to the specific site features and forces that gives them their special status.

The position of the house in Ampleforth offers the chance of a unique interaction between land and architecture that has informed the theme of a 'germinating house'. This theme has subsequently developed to be representative of an innovative house typology using the conceptual notion of a 'seeds growth' as the key guiding principal to inform the appearance.

The proposals also follow the principles found in 'organic architecture' with natural, softened sinuous forms that grow out gently on the hillside and have been designed to maximise the area of south facing envelope for solar advantage. The rhythms and undulations of the organic forms offer further layers of abstract symbolism: For example the semantics associated with disrupting the earth underground, roots, leaves etc. The result is a sense of multiple visual interpretations and richness to the onlooker.

## 4.2 Sustainable Strategy

The team's approach to the technical innovation meeting the Para 79 test is based on the understanding that most sustainable strategies have been around for a long time; what gives these strategies their novelty is the materials and technology to deliver these strategies, how well they are integrated with one another and how they are incorporated into the overall building – techniques unusual in a domestic setting.

### A. Energy Strategy

The energy strategy for the building is set out in a separate report by The Ethical Partnership. The design is based on creating an Earth - Energy Bank (EEB) storage, energy coming from different sources. Hybrid Photovoltaic and Thermal modules (PV-T) and the passive solar collectors will generate the energy to be stored in the EEB.

### B. Passive Conditioning using Form, Fabric and Solar Gain

As previously mentioned, the energy strategy has an influence on the overall form of the building by maximising beneficial gain during the heating season and shading and ventilating the building in summer to minimise heat build-up. The South facing linear form maximises the solar exposure. The glazing to the living spaces and the cleverly placed light wells (the seeds) avoid the need for the use of artificial light during the day.

Solar energy will be stored underground, via the innovative Energy Bank. Solar shading, in combination with opening windows and vents on opposite sides of the living spaces, will provide the control of peak summertime temperatures. Ventilating the building at night in summer will enable the thermal mass to reduce peak temperatures by allowing cooler night air to remove excess heat from the building. This will be automatically controlled in a Building Management System to minimise energy demand.

### C. Fresh Air Ventilation for Occupants Incorporating State of the Art Heat Recovery

Fresh air ventilation is necessary for building occupants, however, in winter can contribute to a significant energy consumption. This will be minimised with a bespoke Mechanical Ventilation and Heat Recovery (MVHR) System coupled with the PV-T and solar collectors. The MVHR system will push fresh air through ducts in the floors and walls with ultra energy efficient fans. The Canadian wells (earth pipes) ducts are to be designed to operate as a passive system using convection currents through the light wells. Electricity used to power the fans will be minimised by ensuring the fans only operate when necessary to maintain air quality. Automatic control will ensure that optimum heat recovery and passive cooling is achieved throughout the year.

### D. Water Collection

A system of rainwater harvesting collectors will provide a source for water irrigation and garden water. Foul water treatment is proposed using a package treatment plant to minimise disturbance to the site.

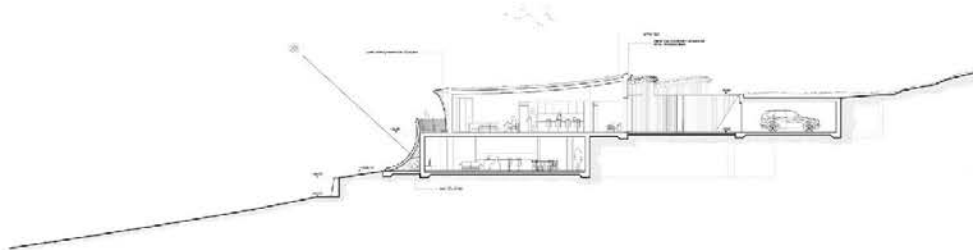

Copy of Proposed Section (not to scale)

## 4.0 SCHEME DESIGN

### 4.3 Sensitivity to the Defining Characteristics of the Site

#### Scale and Arrangement

The scale of this building is designed to integrate well into its site. The house grows from the bottom up like a living organism, taking full advantage of solar exposure, allowing occupants physical and visual contact with the context and the pond. The massing is broken down into a sinuous series of leaves of different size, interconnected by a curved facade. Semi intensive green roofs top each of the leaves and subsequently allows the landscape to flow over the building.

#### Materiality and Referenced Local Imagery

The building appearance has been developed from a palette of simple materials, blackened timber and rusty steel to reference to the vernacular rural buildings in the UK. Leaves roofs flashings and details are proposed in pre-patinated green copper, to beautifully blend to the hillside.

### 4.4 Site Planning

A landscape and visual impact analysis of the proposals has been developed, including the development of an understanding of the appearance of the scheme in the landscape when seen from distance. The characteristics of the landform form a truly magical place which is naturally secluded and creates a place to come upon in the dramatic landscape setting; a place sympathetic to its location.

There are significant net conservation benefits offered by this application, including a range of biodiversity enhancements, as outlined in the accompanying Landscape Statement. In addition, and from an architectural perspective, in developing the position of the house on the site several factors have been considered in keeping with the need to:

- Impact on the landscape
- The energy strategy
- Degree of isolation consistent with the local area character
- Degree of privacy

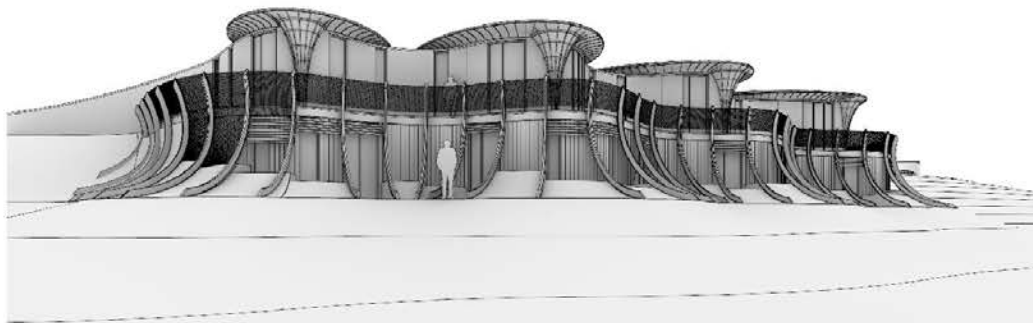

House view from the South West corner of site (climbers and plants omitted for clarity)

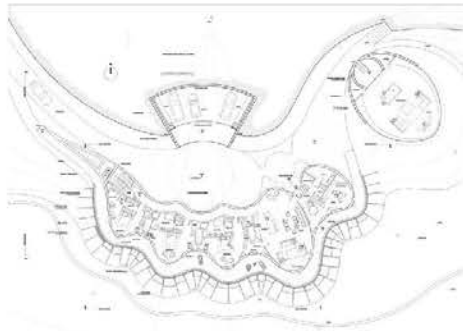

House Upper Level Floor Plan



House Lower Level Floor Plan

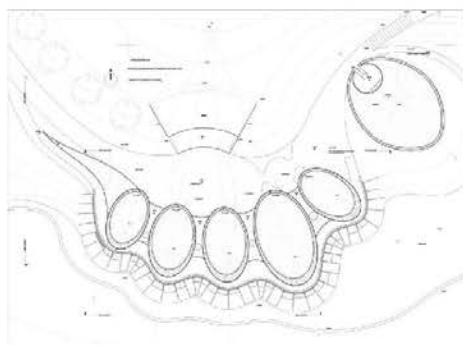

House Roof Plan

Copy of Proposed Floor Plans (not to scale)



SECTION D  
CONCLUSION



## 1.0 MEETING THE REQUIREMENTS OF PARAGRAPH 79

The whole project meets the requirements of the NPPF Paragraph 79 in terms of the quality of its design, materials and innovative technologies.

At Sadler Brown we believe firmly in the genius loci of the site. The site emits a natural energy which can be divined to inform the site for the man-made intervention. We seek to provide a balance between the natural and the man-made. Ecologically benign buildings need to respond to natural forces such as passive solar gain, daylight, natural ventilation and landscape as well as cultural issues such as visual intrusion, light pollution, and accessibility.

To make best use of the site, the building form should be optimised to ensure a best response. Here the wonderful and romantic site context allows us to produce the building form which responds to these forces.

We seek to provide low carbon buildings, not only in operational terms but also in the construction processes. This means that we create the building from low processed and low embodied energy materials. Local suppliers and manufacturing take precedence to allow the building form and structure to be developed.

This is a building sympathetic with its location – socially, economically and ecologically. This project seeks to make a contribution to the exceptional body of architecture in the UK. This is done not by replicating, but by enhancing it to create architecture that is of our time, innovative and contemporary.

NPPF Paragraph 79 reads:

“To promote sustainable development in rural areas, housing should be located where it will enhance or maintain the vitality of rural communities. Planning policies should identify opportunities for villages to grow and thrive, especially where this will support local services. Where there are groups of smaller settlements, development in one village may support services in a village nearby.

Planning policies and decisions should avoid the development of isolated homes in the countryside unless one or more of the following circumstances apply:

- a) there is an essential need for a rural worker, including those taking majority control of a farm business, to live permanently at or near their place of work in the countryside;
- b) the development would represent the optimal viable use of a heritage asset or would be appropriate enabling development to secure the future of heritage assets;
- c) the development would re-use redundant or disused buildings and enhance its immediate setting;
- d) the development would involve the subdivision of an existing residential dwelling; or
- e) the design is of exceptional quality, in that it:
  - is truly outstanding or innovative, reflecting the highest standards in architecture, and would help to raise standards of design more generally in rural areas; and
  - would significantly enhance its immediate setting, and be sensitive to the defining characteristics of the local area.

Evidence to support our compliance with this is provided as follows:

### Exceptional Quality

We have a very strong concept which is expressed in the built form with the underlying principles of Organic Architecture expressed in every detail of the building. The building has been designed at the cutting edge of architecture and technology in the 21st century.

### Innovation

"the exceptional quality or innovative nature of the design of the dwelling." Such a design should be of a type that "help(s) to raise standards of design more generally in rural areas".

As such it should not be interpreted as the need for constant novelty for its own sake as this would not provide transferable solutions. Innovation is not used for its own sake but to create an opportunity for experimentation to provide solutions for the future use of sustainable systems and materials more widely in rural areas. Thus it is not intended that this can be directly replicated but learnt from. This is an organic approach to architecture in its broadest sense.

### Isolated

"To promote sustainable development in rural areas, housing should be located where it will enhance or maintain the vitality of rural communities. For example, where there are groups of smaller settlements, development in one village may support services in a village nearby. Local planning authorities should avoid new isolated homes in the countryside unless there are special circumstances."

The site of the proposed development is located in an area where there are a number of isolated dwellings. The proposed site is isolated sufficiently so as to ensure a standalone feature within a wider landscape setting, but also within short range of good services and transport access.

### Truly Outstanding

What is it that can lift the ordinary to become truly outstanding? After all, a building is a functional object which provides shelter. However, when a building not only satisfies its functional requirement, but also provides 'delight', it has exceeded its function. This building surprises and expands the human experience in the external and internal spaces, views and vista that it creates. It is an outstanding design and truly stands out from the crowd.

### Highest Standards In Architecture

We have interpreted the spirit of reflecting the highest standards as a means of promoting new solutions and experimental methods, which may be directly transferable within the wider context of rural building to create the country houses of the future. This project demonstrates that basic materials can be used in new and innovative ways to provide solutions to contemporary problems associated with rural buildings. This project provides a test bed for the introduction of new methods and materials in construction, which are sustainable and from local sources.

This project follows the tradition of the English country house and its symbiotic relationship between architecture and landscape. It is common, in local communities, to believe that development within the countryside can degrade the open countryside through its intervention. We believe that, in common with the English tradition of building and landscape working together, this project enhances this place, it creates shelter, drama and delight.

It may sound a little harsh but the designs proposed for the majority of new houses in the UK are boring, at best unadventurous and normally just dull. They are often variations on the Victorian vernacular or neo-Georgian theme and more or less mimic the houses that surround them. Even the houses built and designed by self-builders are often very similar to those produced by volume housebuilders.

But it doesn't have to be like this. In design terms, one can argue that the 1930s, 50s and 60s explored every imaginable combination of flat roofs, steel, glass and concrete, and that no design today can ever be described as truly new. But this is not correct.

## 1.0 MEETING THE REQUIREMENTS OF PARAGRAPH 79 (continued)

Contemporary design is that which makes the best use of the most up-to-date materials and ideas in both the technical and aesthetic sense. The fact that some of it may have been done before is not relevant.

A contemporary design can either involve new materials and technology used in a traditional format or the use of traditional materials in a new and innovative design, or it can be a combination of both. In any event, it enables both originality and utility and the house is unlikely to look much like its neighbours.

Where adventurous new designs have been tried, they became local landmarks and have been the subject of positive interest.

A key reason for sticking to neo-traditional design seems to be an expectation that it will be very difficult to get planning permission for anything that could be described as modern or contemporary.

As with any planning application, traditional or modern, the relevant planning policies are critical. Many recent central and local government policy pronouncements actually support and encourage modern design, but there is an ingrained planning restriction to the idea that the development should blend in with its surroundings.

Paragraph 79 sets the tone for the Government's support for contemporary architecture and high environmental standards in design. It gives great emphasis in all their planning documents to sustainability and this concept includes energy efficiency and the effective use of land.

Contemporary design and architecture can be used to maximise the use of a site, whilst minimising visual impact and also to incorporate the very best in energy efficient technology.

### Raising Standards Of Design

Traditionally, most houses in the countryside were of a plain, rather austere character. The only exceptions were the mansions of estate owners or some more ornate houses erected in the Victorian periods. In recent years however, there has been a marked tendency for new dwellings in the countryside to adopt the style and appearance of typical suburban development of the period e.g. mock Georgian and Tudor. Whilst some of these styles may not look out of place in a housing estate in a town, they are generally incongruous in a rural setting. They have the effect of debasing the distinctive regional character and blurring the contrast between town and country.

However, this project seeks to prove that things can be done differently, but by still using vernacular materials.

This project shows that it is possible to create beautiful and delightful forms and places within the countryside, drawing its inspiration from the very earth in which it sits. Providing exemplar examples of how this can be achieved is one of the merits patrons of country houses can provide for future generations to enjoy.

### Enhancing The Setting

This scheme will bring a sustainable place not only in terms of its energy efficiency, but also to provide food and fuel to create a harmony between habitation and landscape. It will provide places for storage and amenity for the human occupants, but also provide new habitats and an ecosystem to enhance the wild nature of this place in a managed manner. In addition to the significant enhancement of setting that is offered by the introduction of a new work of architecture and biodiversity enhancements that are proposed as part of this application are also enriched for future generations to enjoy.

### Charm/Sensitivity To Local Area

The character of this area is a relatively diverse one with many examples of every period of architecture, and its fair share of poor quality housing and agricultural structure. Our approach is sensitive and provides a building form which with the use of high quality natural materials will weather well and sympathetically and enhance the predominant features of this area.



SECTION E  
APPENDICES

## APPENDIX 1.0 NOVEMBER 2017 DESIGN REVIEW PROPOSALS



The document has been designed for A3 (297 x 420 mm) print.  
This page is intentionally blank.

## PREFACE

The document has been prepared for A3 (297 x 420 mm) print.

All of this document is to be consulted only with the Local Council's consent.  
It is subject to the provisions of the Access to Information Act.

This document should be read in conjunction with the Local Council's Access to Information Act.  
Local Council's Access to Information Act and the Local Council's Access to Information Act.



SITE LOCATION



Image from Bing Maps. Courtesy of Yorkshire Survey



SUN PATH

SUMMER SOLSTICE



SPRING/FALL EQUINOX



WINTER SOLSTICE

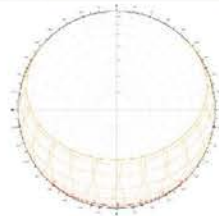
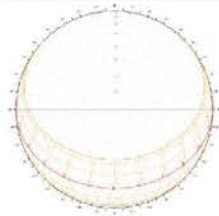
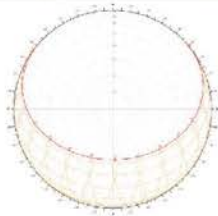

CHARACTER OF THE SITE



skulptur 2



skulptur 1

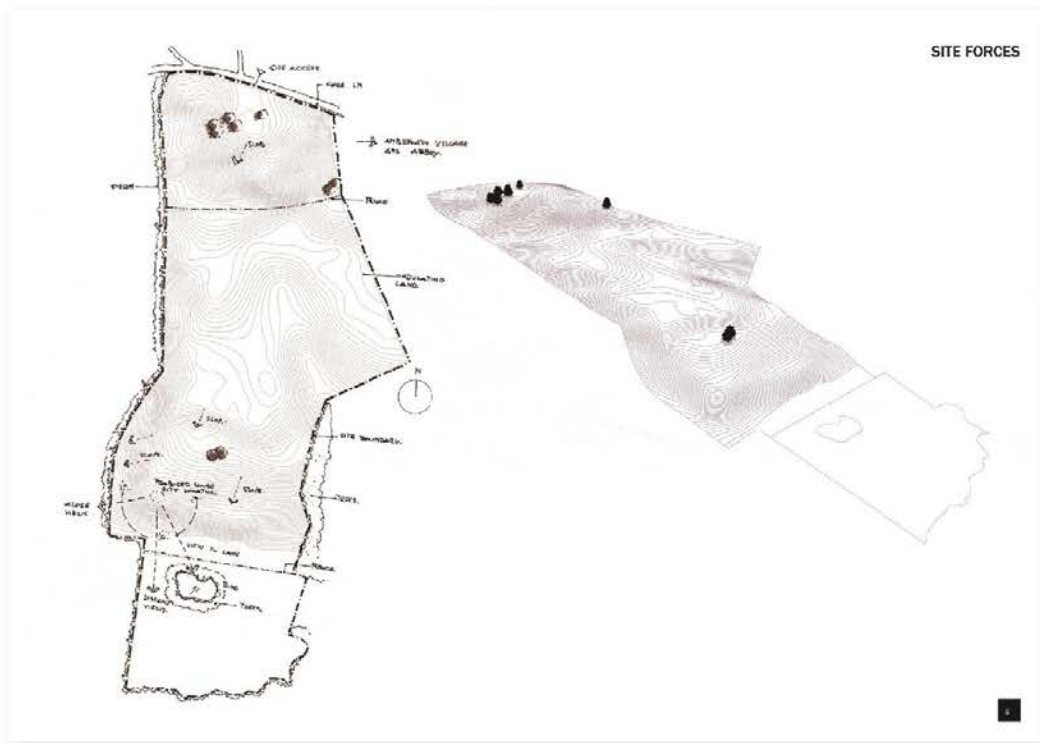

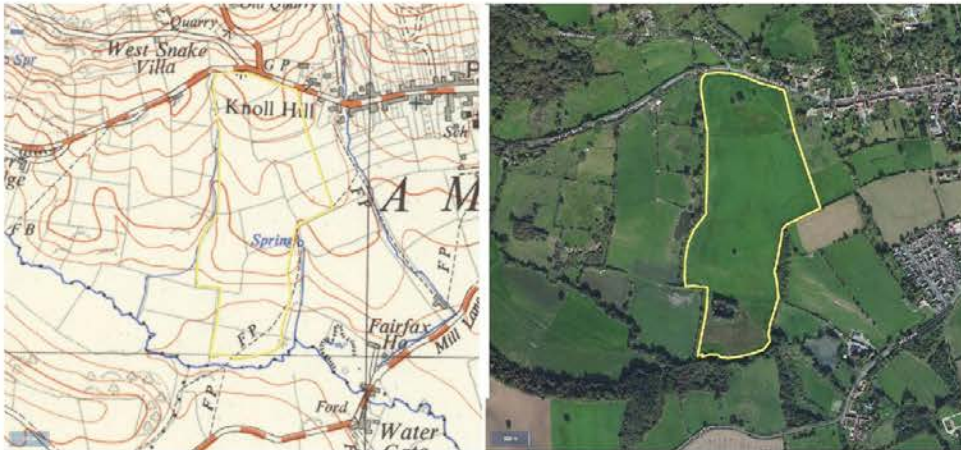

THE BRIEF

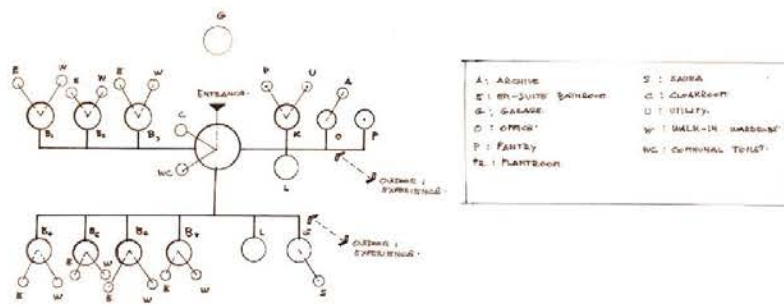

Metaphor of seed growth  
from ground  
to have line a plant  
in parts with different growth rates.

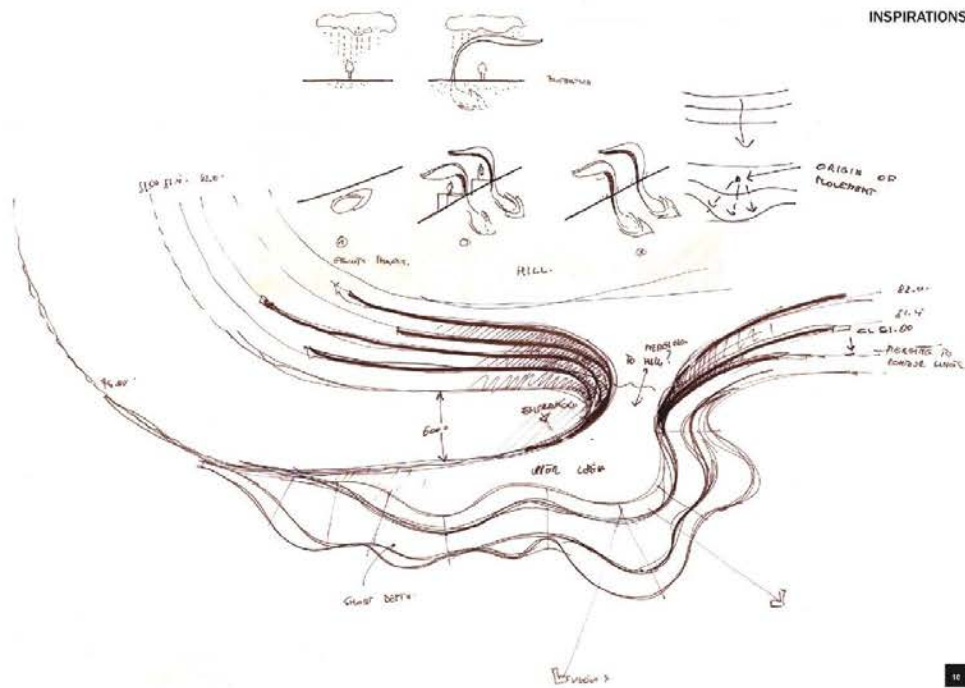

INSPIRATIONS

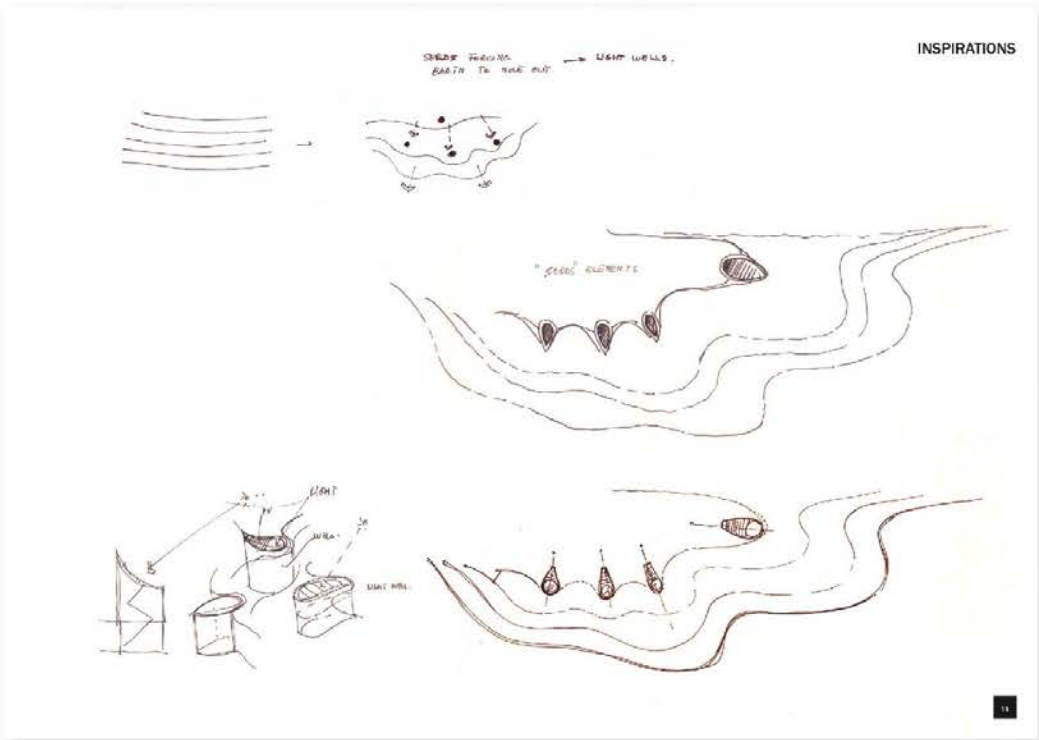

INSPIRATIONS

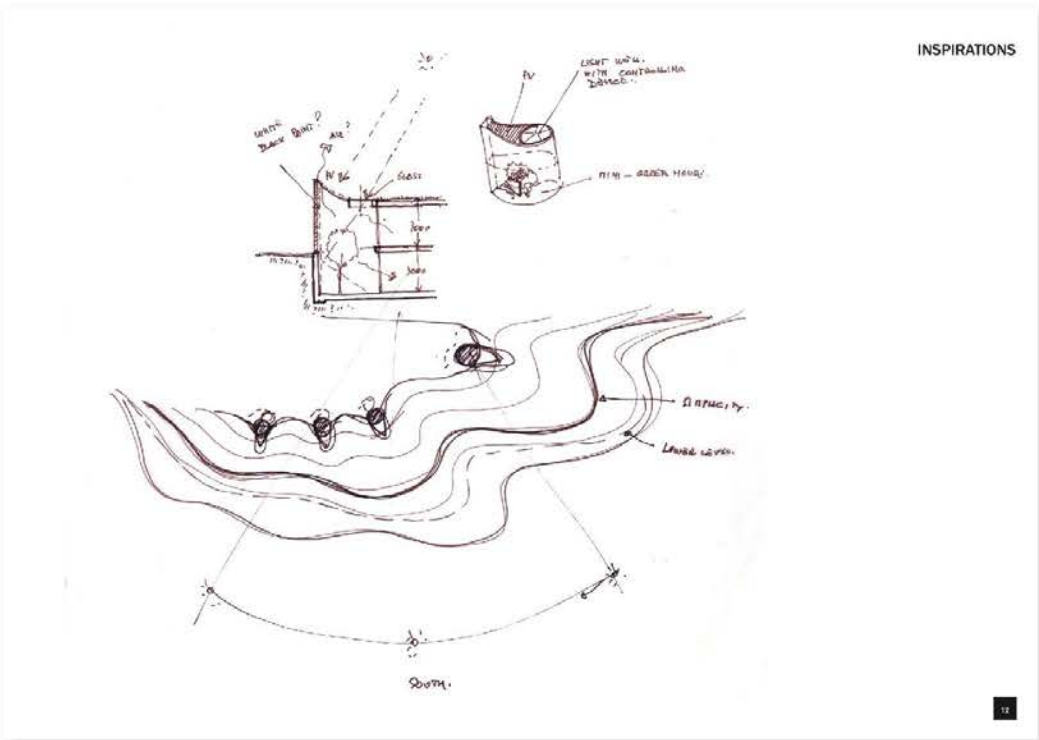

INSPIRATIONS

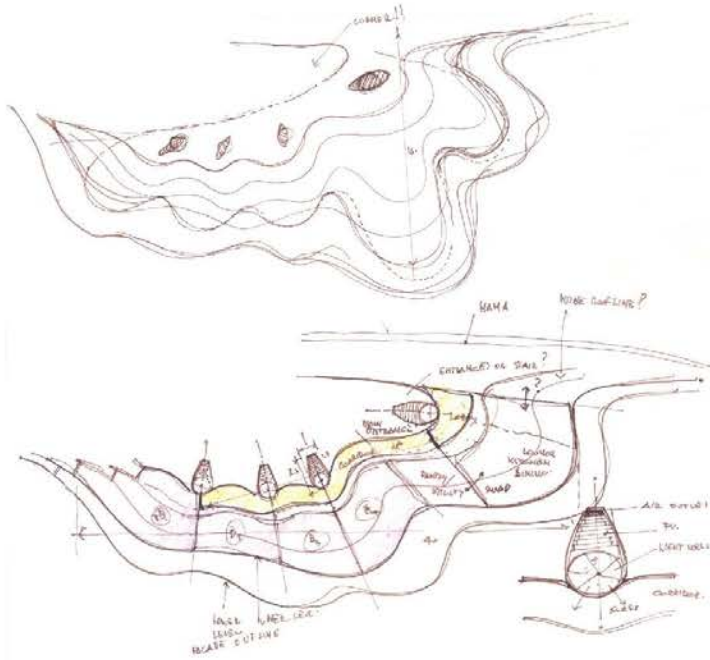

3

CONCEPT DEVELOPMENT

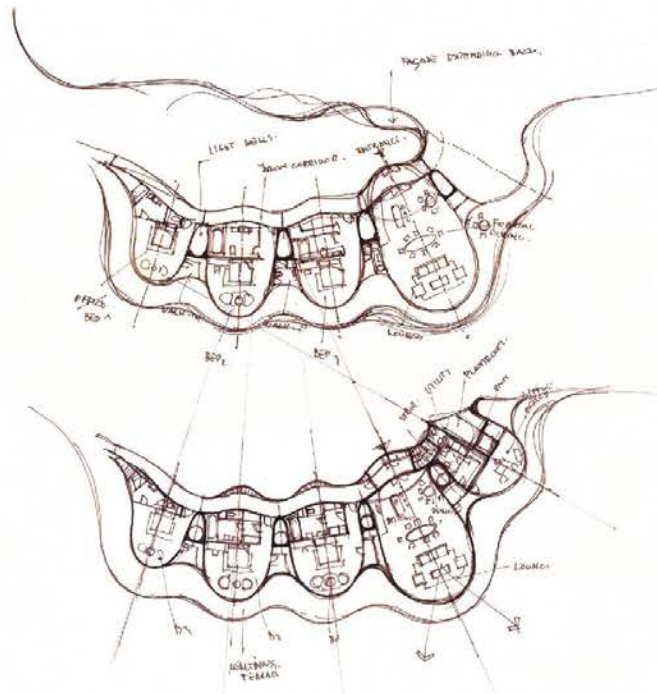

4

CONCEPT DEVELOPMENT  
UPPER LEVEL

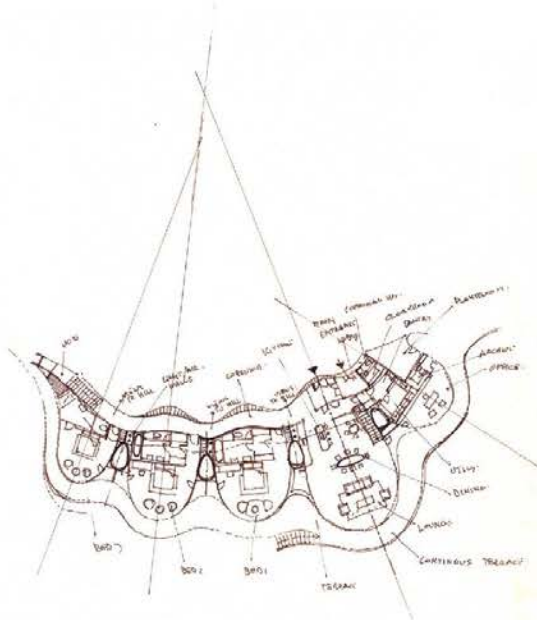

11

CONCEPT DEVELOPMENT  
UPPER LEVEL

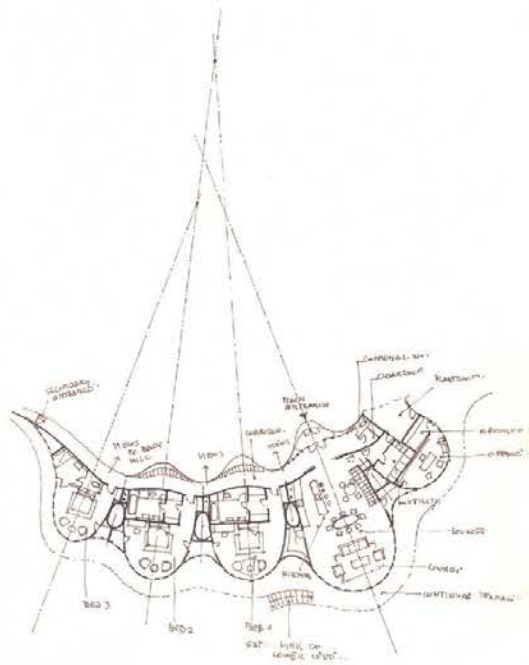

12



CONCEPT DEVELOPMENT  
UPPER LEVEL

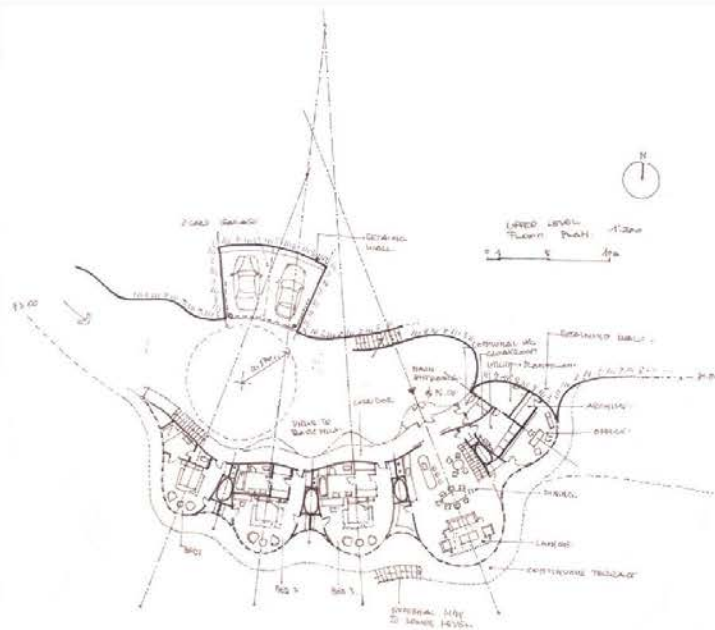

10

CONCEPT DEVELOPMENT  
LOWER LEVEL

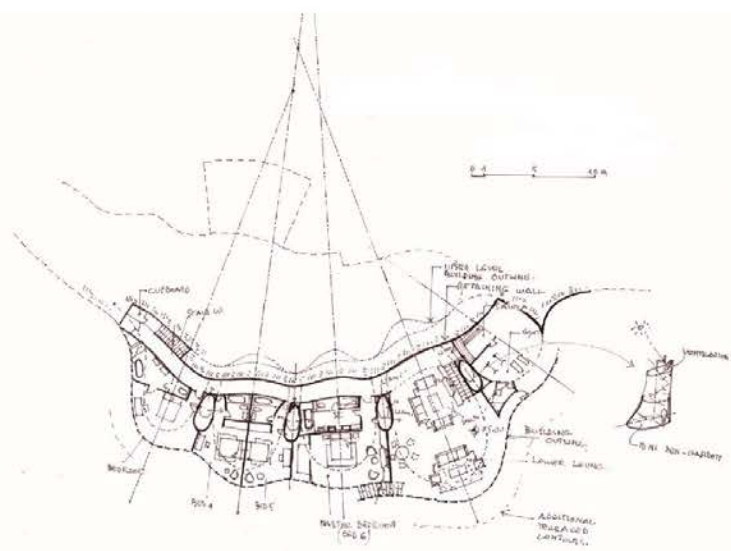

11

CONCEPT DEVELOPMENT  
ROOF LEVEL

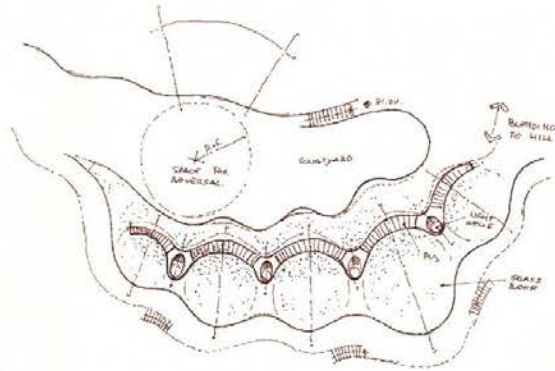

PROPOSED FLOOR PLAN  
UPPER LEVEL

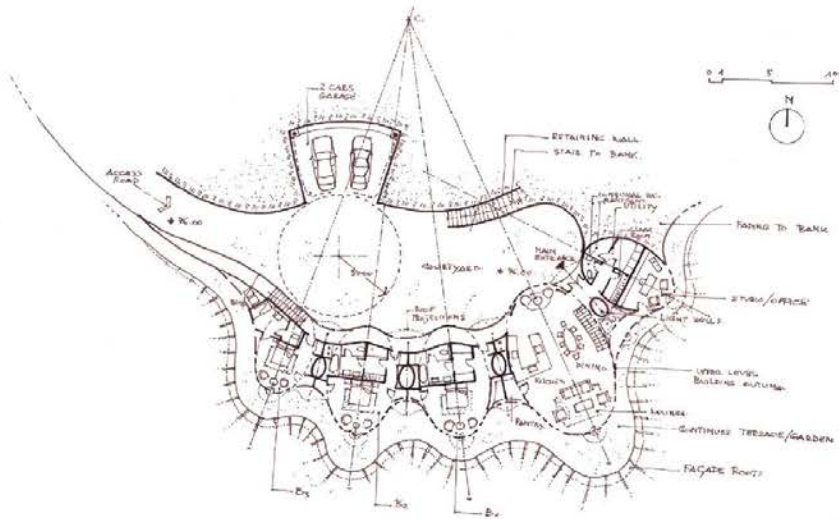

PROPOSED FLOOR PLAN  
LOWER LEVEL

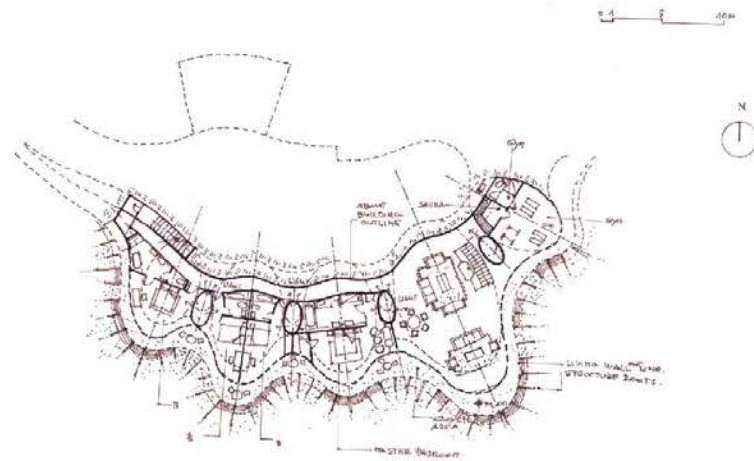

21

PROPOSED ROOF PLAN

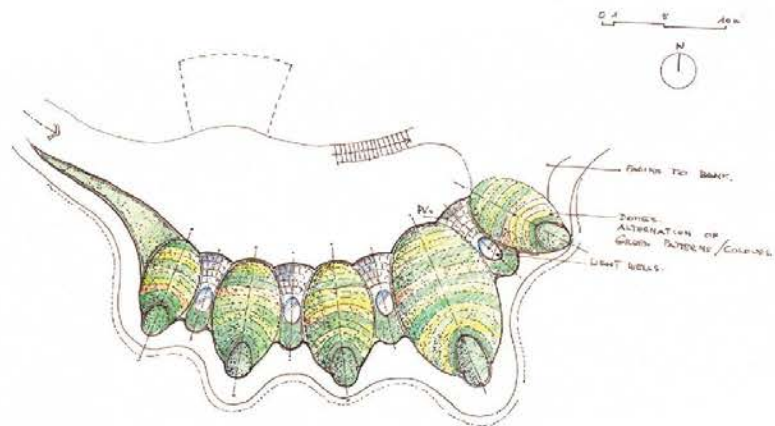

22

PROPOSED SITE PLAN

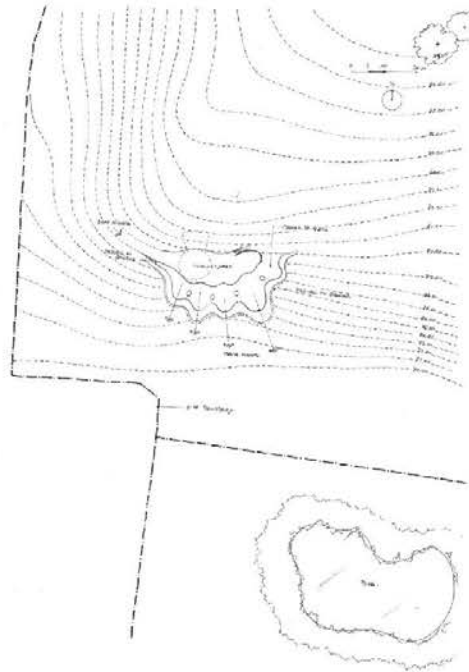

21

PROPOSED SECTION A-A

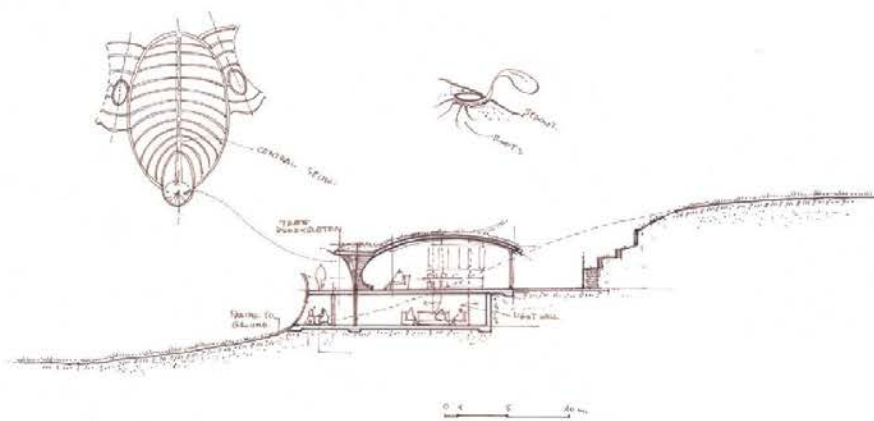

22

FACADE STUDY

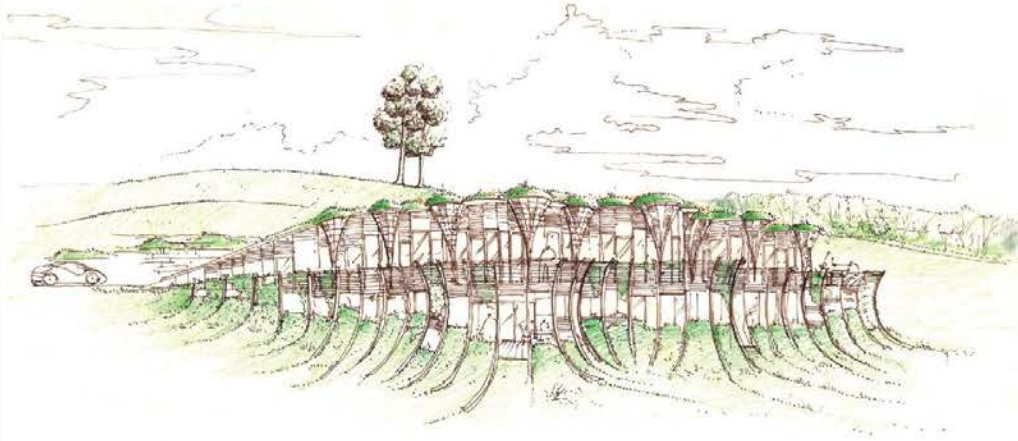

FACADE STUDY

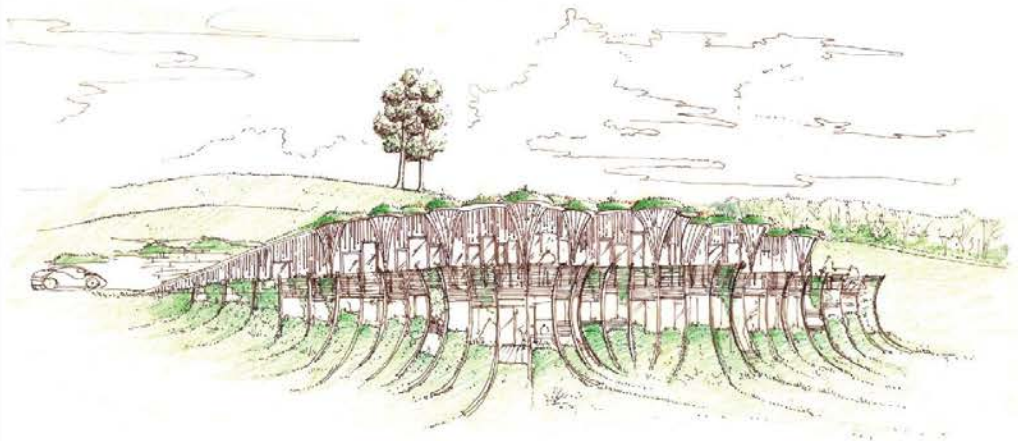

PRECEDENTS  
LIGHT WELLS



PRECEDENTS  
GREEN ROOFS



PRECEDENTS  
CLADDING



31

SADLER BROWN ARCHITECTURE

11/12 RIVERSIDE STUDIOS  
AMETHYST ROAD  
NEWCASTLE UPON TYNE  
TYNE AND WEAR  
NE5 7YL  
T: +44 (0) 191 265 7000

## APPENDIX 2.0 2017 DESIGN REVIEW FEEDBACK



## Design Review Report

YDRS 204, Dwelling in Ampleforth  
Design Review 1

Design Review Service for Yorkshire and the Humber



**Status of report:** CONFIDENTIAL  
**Date of Review:** 29<sup>th</sup> November 2017  
**Location of Review:** The Fairfax Arms, East Gilling

---

**Scheme Description:** Insertion of a contemporary new home into the landscape, restoring and reinforcing the characteristics of the local landscape on land to the west of Ampleforth.

**Stage of Planning:** Conceptual architectural and sustainability design (Part of RIBA Stage 2)

**Background:** LPA recommended the scheme comes to YDRS to help achieve criteria set out in Paragraph 55 of the NPPF.

**Proposals submitted for Review:** Design concept brochure, sustainability brochure and landscape master plan document.

**Scheme Representatives:** Matthew Creedy, Ethical Partnership, Planning consultant  
Kevin Brown, Sadler Brown, Director  
Luca Biselli, Sadler Brown, Associate Designer  
Alex Robinson, The Landscape Agency, Landscape Architect

**Panel Members:** Tom Lonsdale, Vice-Chair, Landscape Architect  
Ric Blenkharn, Architect  
Robin Macnoll, Architect  
Dave Hickling, Chartered Town Planner

**Observers:** Ed Tawcett, Client and Landowner

**YDRS Staff:** James Wilde, Design Review Manager  
Robbie Drumrod, Design Review Assistant

---

Supported by



info@integrateplus.com  
www.integrateplus.com

---

### Summary of panel comments:

The Panel thanks the project team for bringing this scheme to the Yorkshire Design Review Service. The Project team are commended for engaging in a Review at the initial conceptual design stage. It is often the most beneficial time to bring projects to Review, allowing time for the project team to develop and strengthen designs and proposals in response to any guidance and suggestions provided. It does however limit the Panel's ability to comment on whether or not they believe the design currently satisfies the criteria set out in Paragraph 55 of the NPPF. Instead the comments and guidance will seek to encourage the Project team to explore options which they believe will help the design fulfil the criteria moving forward.

Following a clear and eloquent presentation and a productive two-way discussion, the Panel feel the most important aspect to address is articulating and justifying the rationale behind the selection of this site for the dwelling, and communicating the long-term strategy for the management of the entire land holding and its integration into the wider landscape.

In summary, this is a novel and distinctive project that shows signs of high quality work, especially in the development of an architectural philosophy for the building form. As the design process evolves the inclusion of high quality, locally sourced materials could help deliver an outstanding and exceptionally designed home that satisfies the design criteria set out in Paragraph 55 of the NPPF if the siting issues can be justified to the satisfaction of the Planning Authority.

The following comments are for the project team and local authority's attention.

In summary, these are to focus on the:

- **Location and siting of the proposed dwelling**
- **Landscape strategy and site management**
- **Sustainable technologies and design**
- **Other comments (architecture, materials, local context)**

Supported by



2

info@integrateplus.com  
www.integrateplus.com

Panel comments:

**Location and siting of the dwelling:**

The location and siting of the dwelling is a critical element of this proposal. The project team should explain and justify why the proposed siting of the house is the best option, both in terms of the overall site's location and the detailed siting of the house within that land. Site selection is dealt with in the next section but more work is required in justifying where the house is to sit within the fields chosen, for instance why locating the house closer to Jerry Carr Bank and Knoll Hill is, in this instance, not considered appropriate. The Panel recognise that the chosen location further down the site responds well to the client's brief for an intimate family home that interacts well with the landscape. It also provides greater opportunities for the house to engage visually and physically with the land and would foster a stronger relationship with the pond, trees, hedgerows and wider landscape. The Panel are, on balance, persuaded by the arguments offered at the Review for this justification and feel the result is a home that appears to be delicately nestled into the hillside. It is agreed that developing close to Knoll Hill would result in a home which is highly visible from key viewpoints, potentially dominating and detracting from the landscape setting. A house that is perched, looking down on to the village may be considered too imposing and possibly even arrogant in this sensitive context. If the house was located at the northern end of the site the connection with the land to the south would be purely observing the distant views rather than a more harmonious and tangible interaction.

The wider pattern of local development can be observed as a ring of isolated farm and homesteads dotted around the village. The project team should demonstrate how this proposal reflects and responds to this pattern of rural development.

The Panel understand that it is not the intention to hide the house and agree that exemplary architecture should not be hidden. The proposal presents an opportunity to offer views and glimpses of the house from the nearby public right of way which stretches from the southern end of the site along the eastern boundary.

Domestic curtilage should be carefully considered and boundary treatments between garden and the rest of the site are crucial to integrating the house into the landscape. A more intimate and discreet garden space can be achieved through the placement of the house on this part of the site as the topography of the land can be utilised and exaggerated to accommodate and seclude domestic spaces. The use of red and blue boundary lines on the application can help better communicate the division between domestic curtilage and the broader landscape strategy.

A potential issue with siting the house at the bottom of the field is that it would require a long access road which would be resource and energy intensive. The long access road could make for an interesting, even poetic, journey down to the house, working with the existing contours of the site and screened by additional planting as proposed but fundamental justification for its existence would need a clear and robust narrative, which is addressed fully in the next section.

Supported by



3

info@integreatplus.com  
www.integreatplus.com

### Landscape strategy and management:

A common expectation of Paragraph 55 development is that it provides a practical and financial vehicle for significant enhancement of the landscape. Justification for selection of this piece of agricultural land is made problematic because the land cannot be regarded as significantly damaged or derelict. There are, however, actions that could be proposed as part of the application that would deliver a richer and more interesting local landscape, perhaps even with economic benefits.

Active pasture management is encouraged as a minimum, as this would help restore and maintain parts of the field, but a more intensive and polycultural use of the site should be explored. It is conceivable that restoration of a smaller field pattern, not necessarily slavishly modelled on previous layout, could achieve the dual benefit of bringing back a scale compatible with the wider scene and justifying the length of new access road. This management strategy should be resolved more clearly before fixing an alignment for the road and designing the boundary treatment between the domestic curtilage and its agricultural environs. Bespoke designs that have clear origins in the functions of land on either side will be important components of any design claiming to be outstanding.

The Projects team's intention to increase biodiversity on site through the several measures including enlarging the pond, adding an aquatic habitat to the marshland and additional native planting is welcomed by the Panel. The inclusion of a boardwalk to improve the public right of way to the southern end of the site provides a sense of giving back and adding to the site to benefit its users. A more radical questioning about how the pond relates to and interacts with the marshland, the house and the pasture land in different directions should be pursued.

Supported by



### **Sustainable technology:**

The Panel note that it is becoming increasingly difficult to demonstrate innovative sustainable design as the benchmark is constantly being raised. What once would have been considered innovative is becoming more mainstream as these technologies or principles are being applied in other projects.

Because of this the Panel feel that demonstrating a comprehensive strategy rather than arguing the design is innovative would be more appropriate. This would fit with the overall environmental and sustainability strategy, which constitutes a series of passive and active technologies and design solutions such as a trombe wall, solar slab, storage batteries, water and ground source heat pumps and PV panels.

The most innovative element is the use of a trombe wall and solar slab in a domestic environment. The project team are unaware of any other domestic examples so it would be important to show that this feature would be feasible in this location. Further investigation and modelling as the design process evolves will help clarify the viability and usefulness of the proposed trombe wall. If successfully proven these should be convincingly conveyed as it would set a precedent that would contribute to raising the standard of sustainable design elsewhere.

Natural wool insulation could perhaps be included as this would relate well to the present use of the site.

### **Other comments:**

It could be useful to bolster the design statement with the client's family history in relation to the village of Ampleforth. As the client's grandparents were descendants of some of the original settlers in the village and the family have remained residents ever since, it strengthens the argument and justification for this proposal. This may not be enough on its own to persuade the Planning Authority, especially as others in the village may have equal claims, so it is important for these and other local connections to be made legible in the way that design detail is invested in the architecture and landscape restoration.

The relevance and evolution of the seed concept should be clearly communicated. Its origins as a response to the orchard at the local Abbey should help root the scheme into the local context. The Panel feel that the design concept has been convincingly followed through from the initial sketches resulting in a distinctive and high quality design concept, with abundant potential for delight in the detail.

The Panel understand and appreciate it is early in the design process but would like to have seen section drawings or sketches that illustrate how the building nestles into the hillside. The relationship between the house and how it sits in the land is critical.

An investigation into local materials to be used and their producers and suppliers will further reinforce how the building is rooted in Ampleforth.

Supported by



Department for Communities and Local Government



5

info@integreatplus.com  
www.integreatplus.com

**Please note:**

- If the subject of this review is a scheme that has been submitted for planning consent, the review findings will be published on the Yorkshire Design Review Service/Integreat Plus website and made available to the relevant Planning Committee. Otherwise, this report will be treated as confidential to the parties present at the Review.
- The Yorkshire Design Review Service is advisory and independent and has no statutory status although aims to add value to the planning process. The Design Review Service advises objectively on schemes regardless of whether they are funded or supported by Integreat Plus or other partner organisations. The views recorded are not formally endorsed by Integreat Plus and do not amount to the provision of a service by the YDRS to the scheme representatives or create an advisor-client relationship.

---

Report drafted by Jamie Wilde, Yorkshire Design Review Service Manager

Checked and approved by Tom Lonsdale, Vice-Chair, Landscape Architect

Issued: 26/12/2017

Sponsored by



6

info@integreatplus.com  
www.integreatplus.com



## APPENDIX 3.0 APRIL 2018 DESIGN REVIEW PROPOSALS





New Dwelling at Ampleforth

# CONCEPTS.

Work in Progress - April 2018

SADI ER BROWN ARCHITECTURE

This document has been designed for 300dpi full colour A3 print.  
This stage is intended to be digital.

PREFACE

This document has been prepared for M22 (see also)

One of the documents is to discuss the early and historical concepts behind a proposed F.O.A. new design at Amsterdam.

This document should be used in conjunction with Landscape Agency Landscape Academy, Landscape Agency Concept knowledge and other professional supplementary information.



"Our thoughts for the future to what we make we are very much a part of the earth's ecosystem, and we are here to help it, according to the best knowledge of nature, the future."

- 1 SITE LOCATION
- 2 SATELLITE VIEW
- 3 SUN PATH
- 4 CHARACTER OF THE SITE
- 5 SITE FORCES
- 6 HISTORICAL MAPS
- 8 BRIEF
- 9 INSPIRATIONS
- 15 CONCEPT DEVELOPMENT
- 20 PROPOSED UPPER LEVEL FLOOR PLAN
- 21 PROPOSED LOWER LEVEL FLOOR PLAN
- 22 PROPOSED ROOF PLAN
- 23 PROPOSED SITE PLAN
- 24 PROPOSED SECTION A-A
- 25 FACADE STUDY
- 27 PRECEDENTS
- 27 PHALLION W/P
- 31 HOUSE W/P
- 34 BARN W/P
- 45 STABLES W/P
- 57 SITE PLAN COMPUTER MODEL W/P
- 65 BARN AND STABLES COMPUTER MODEL W/P
- 69 AERIAL VIEW COMPUTER MODEL W/P
- 69 PRECEDENTS



Ampleforth Topographic Map, Courtesy of OS/Burton Brown



SUN PATH

SUMMER SOLSTICE



SPRING/FALL EQUINOX



WINTER SOLSTICE

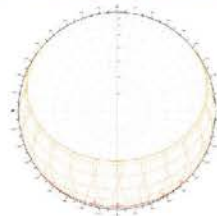
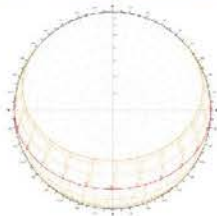
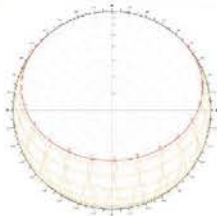



CHARACTER OF THE SITE



04

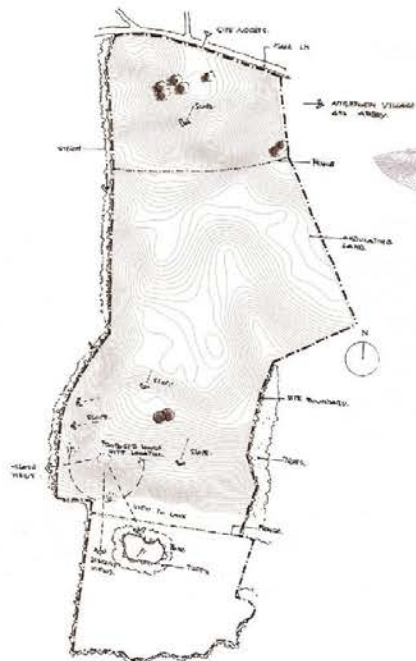

SITE FORCES

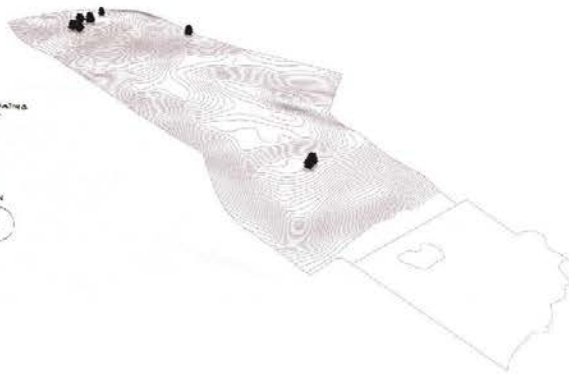

05

**HISTORICAL MAP 1888-1913**  
Source: National Library of Scotland/Bing



1

**HISTORICAL MAP 1937-1961**  
Source: National Library of Scotland/Bing

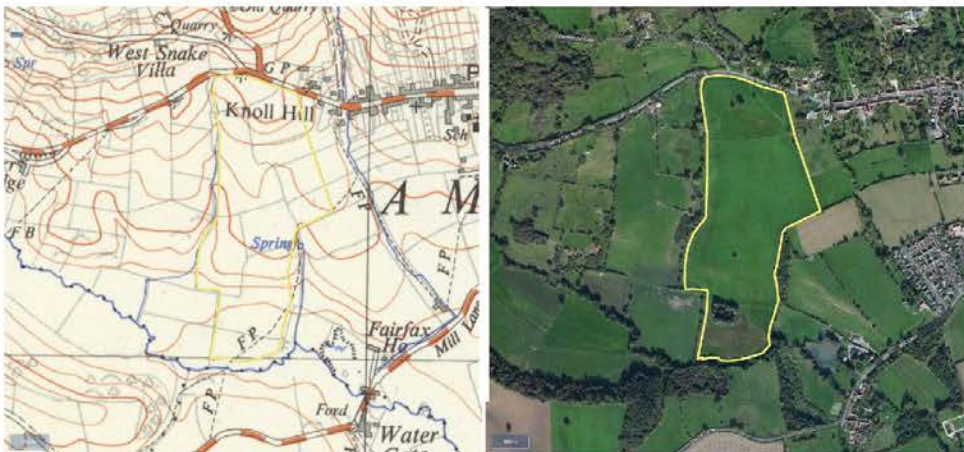

2

THE BRIEF

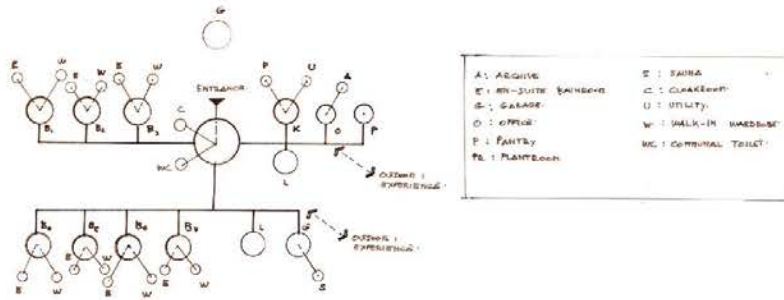

INSPIRATIONS  
SEEDS GERMINATION

INSPIRATION OF SEEDS GERMINATION  
FROM NATURE  
A SEED LING A SPROUT  
A PLANT WITH DIFFERENT GROWTH LEVELS



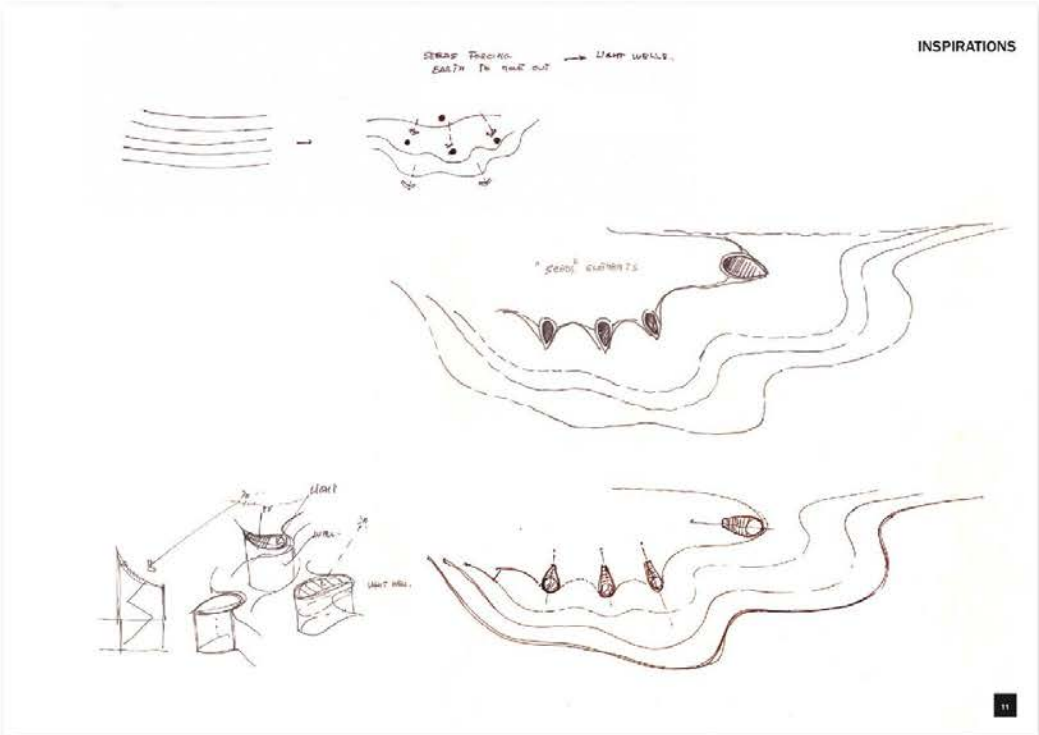
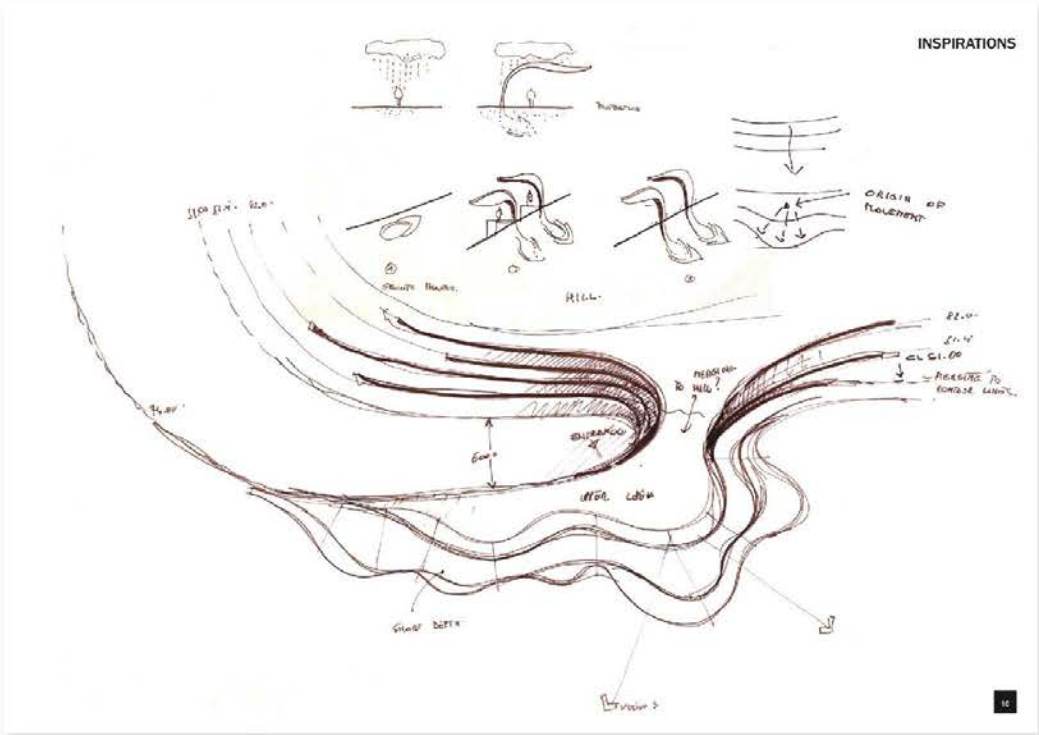



INSPIRATIONS

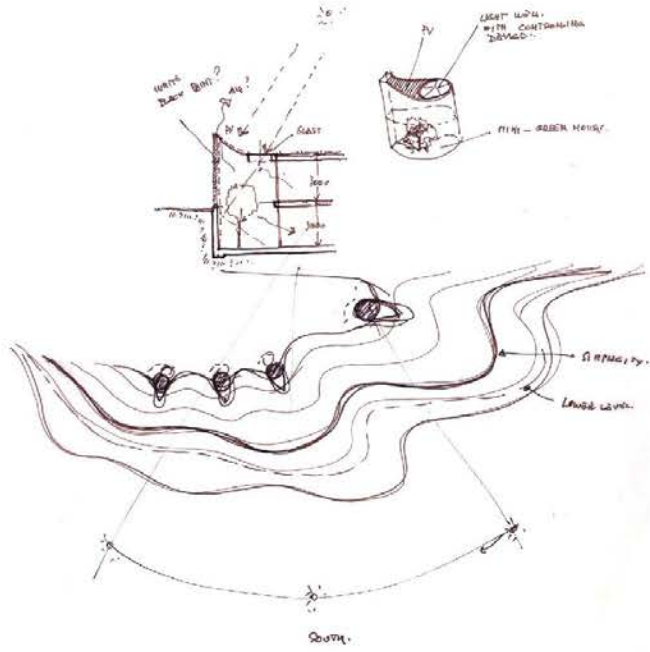

12

INSPIRATIONS

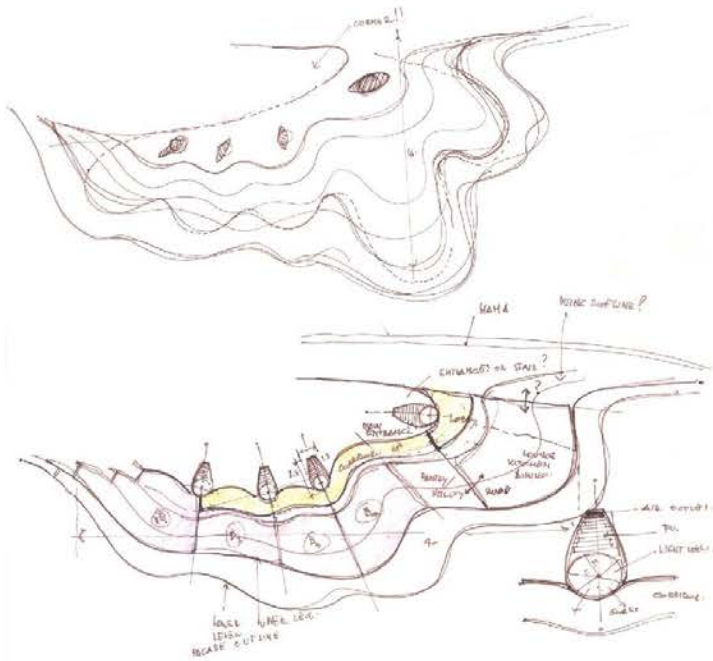

13

CONCEPT DEVELOPMENT

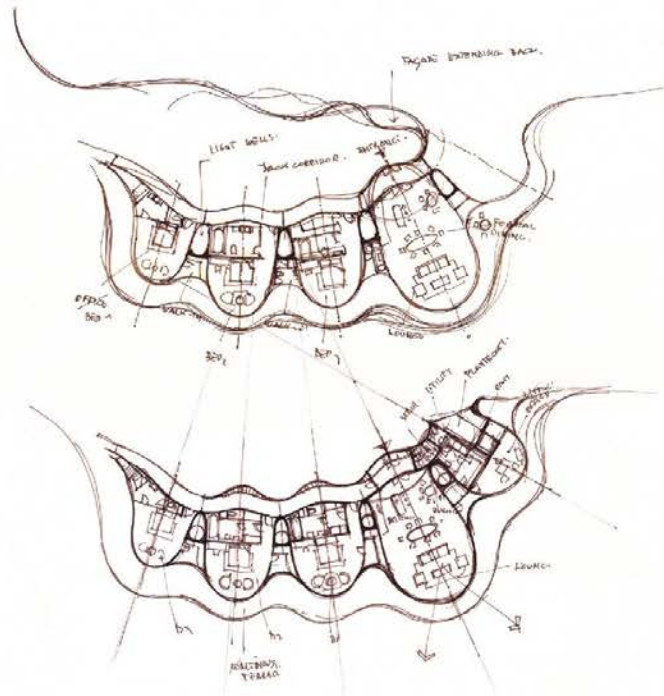

11

CONCEPT DEVELOPMENT  
UPPER LEVEL

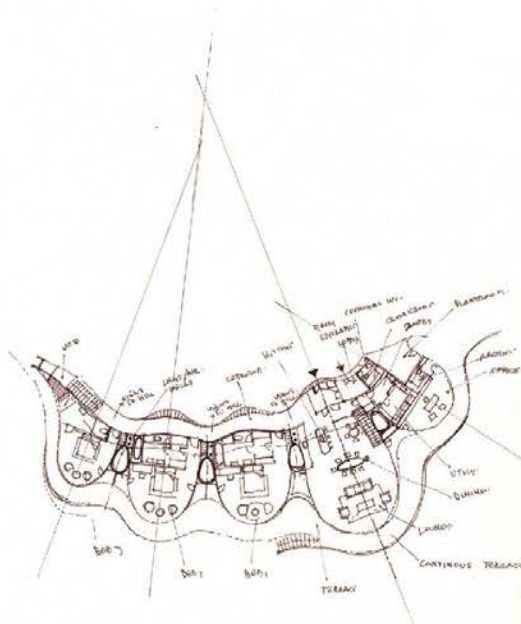

12

CONCEPT DEVELOPMENT  
UPPER LEVEL

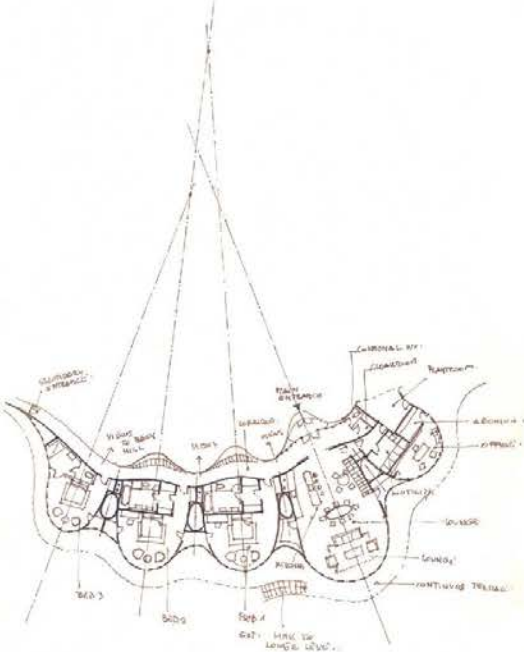

14

CONCEPT DEVELOPMENT  
UPPER LEVEL

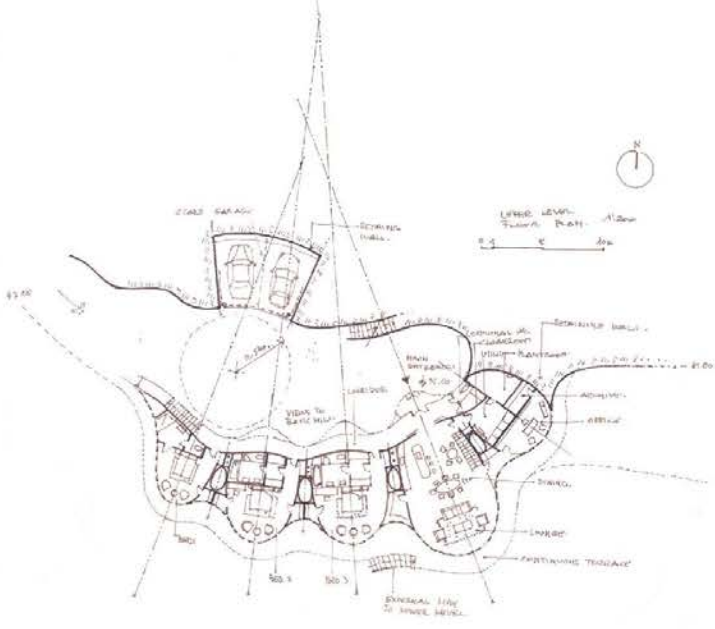

15

CONCEPT DEVELOPMENT  
LOWER LEVEL

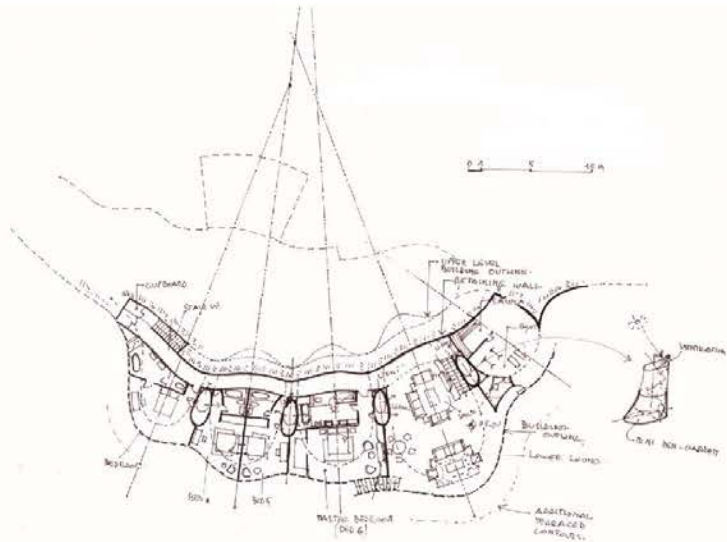

11

CONCEPT DEVELOPMENT  
LOWER LEVEL

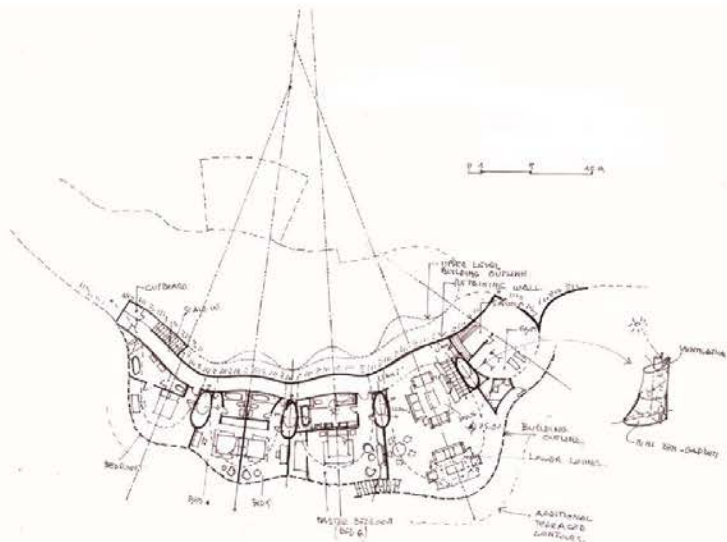

12

CONCEPT DEVELOPMENT  
ROOF LEVEL

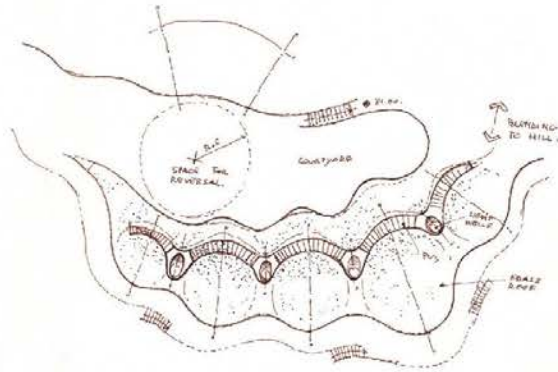

14

PROPOSED FLOOR PLAN  
UPPER LEVEL

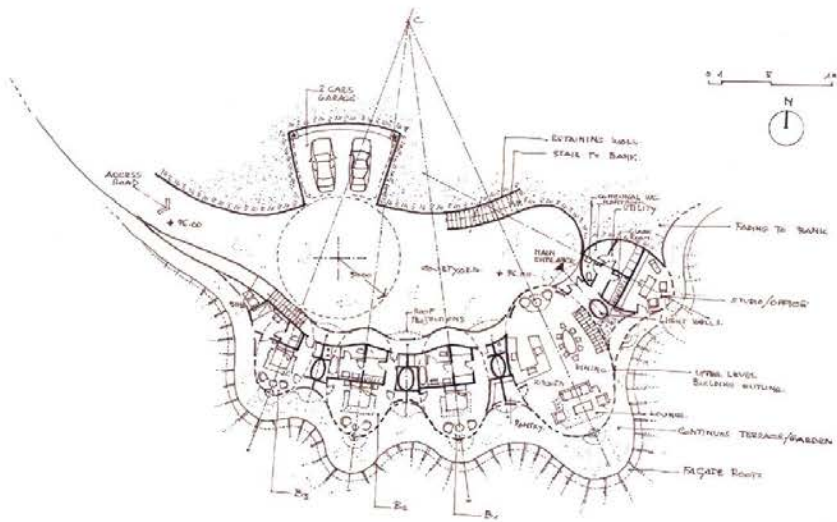

15

PROPOSED FLOOR PLAN  
LOWER LEVEL

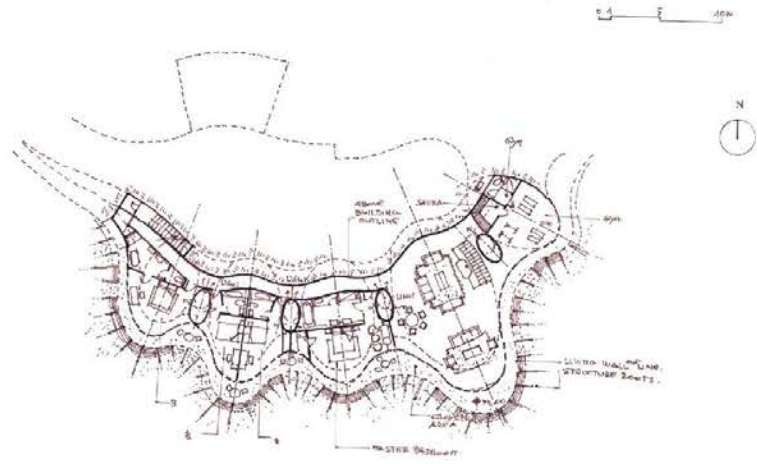

21

PROPOSED ROOF PLAN

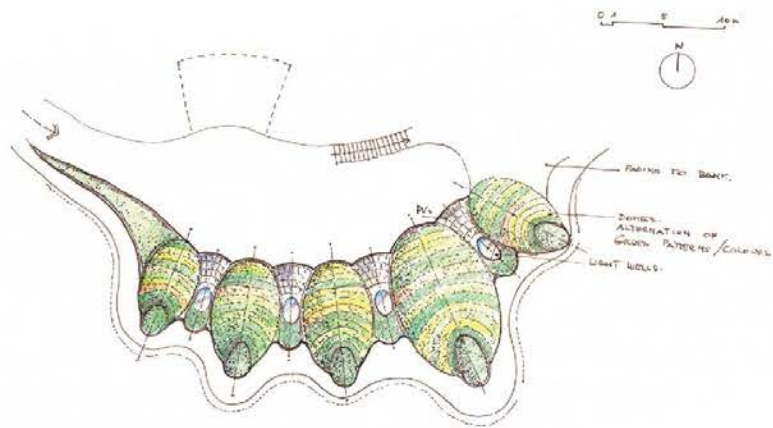

22

PROPOSED SITE PLAN

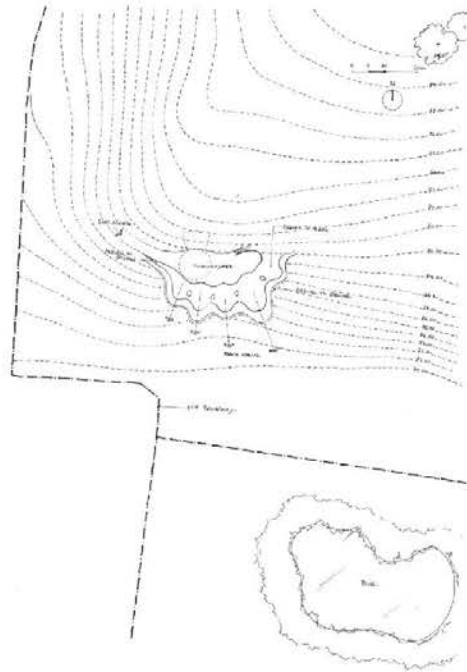

23

PROPOSED SECTION A-A

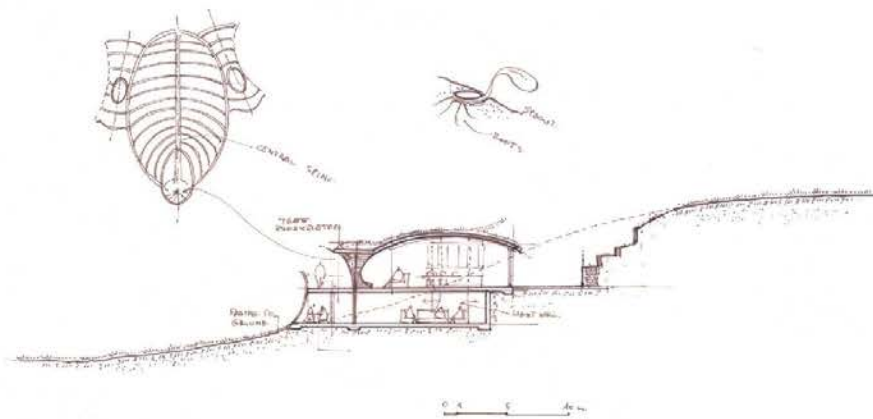

24

FACADE STUDY

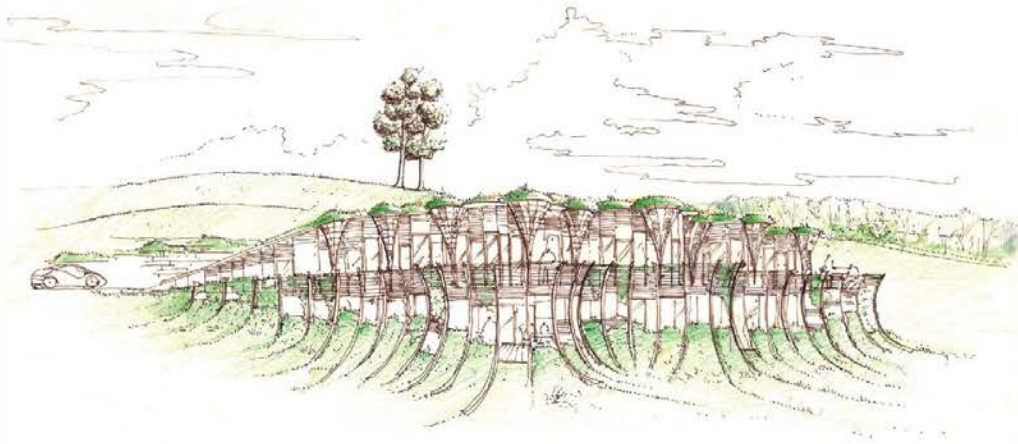

28

FACADE STUDY

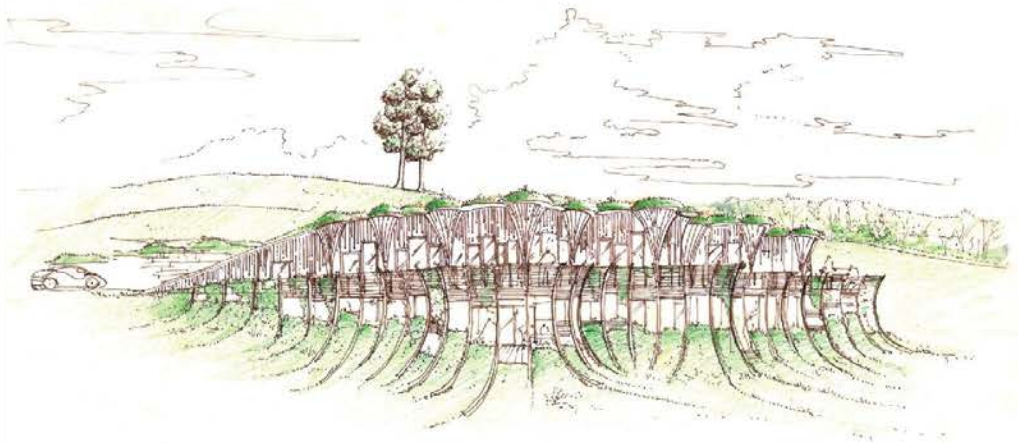

29



This document illustrates the Work In Progress following the YDRS Design Review dated 29.11.2017.

Below are summarised the actions been taken.

- 1. Barn addition to host apples production and hay storage.
- 2. Stables for four horses addition.
- 3. Separated Pavilion for entertainment purpose addition.
- 4. Garage enlarged to accommodate 4 cars.
- 5. Split road access, separating house access from farmstead access.

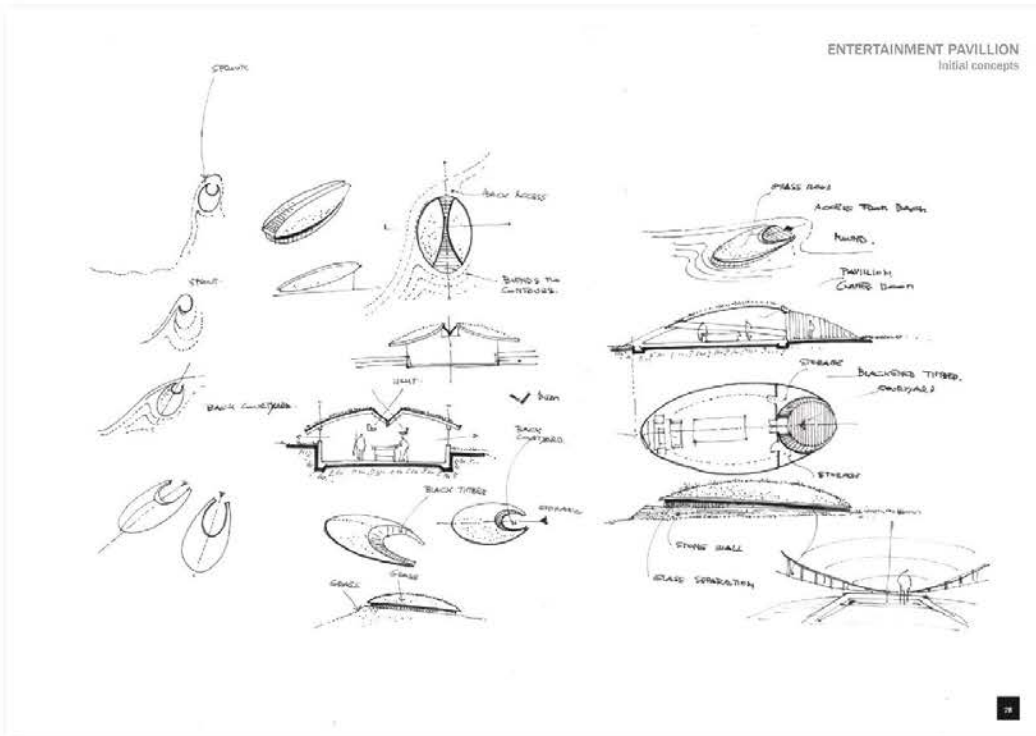

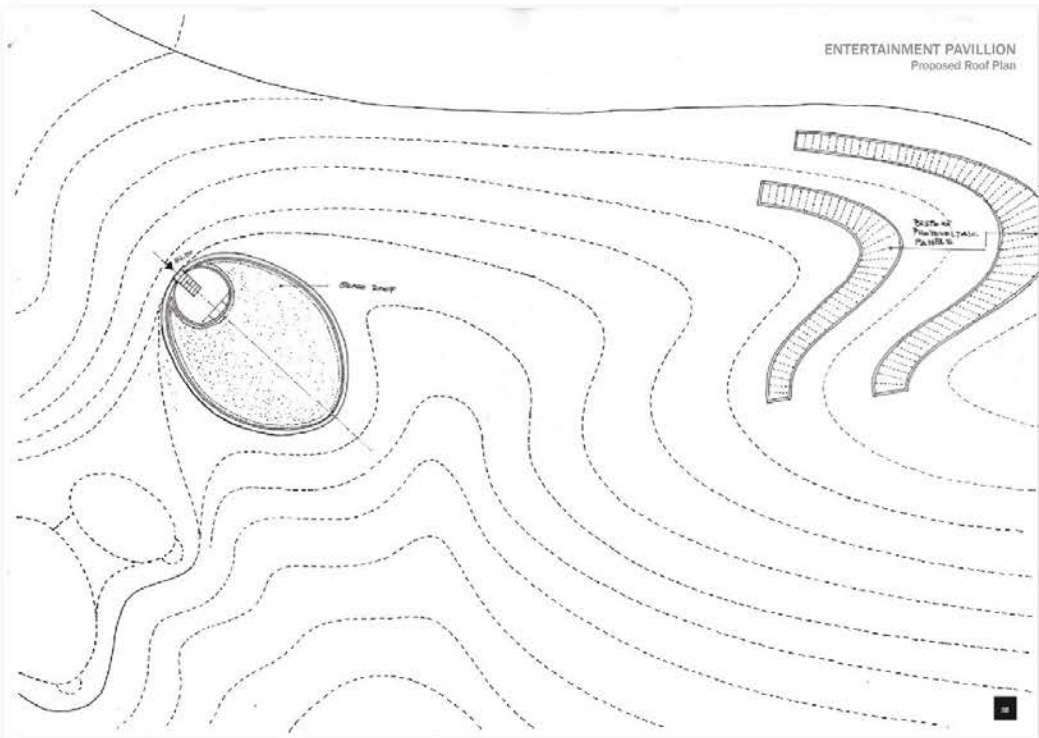
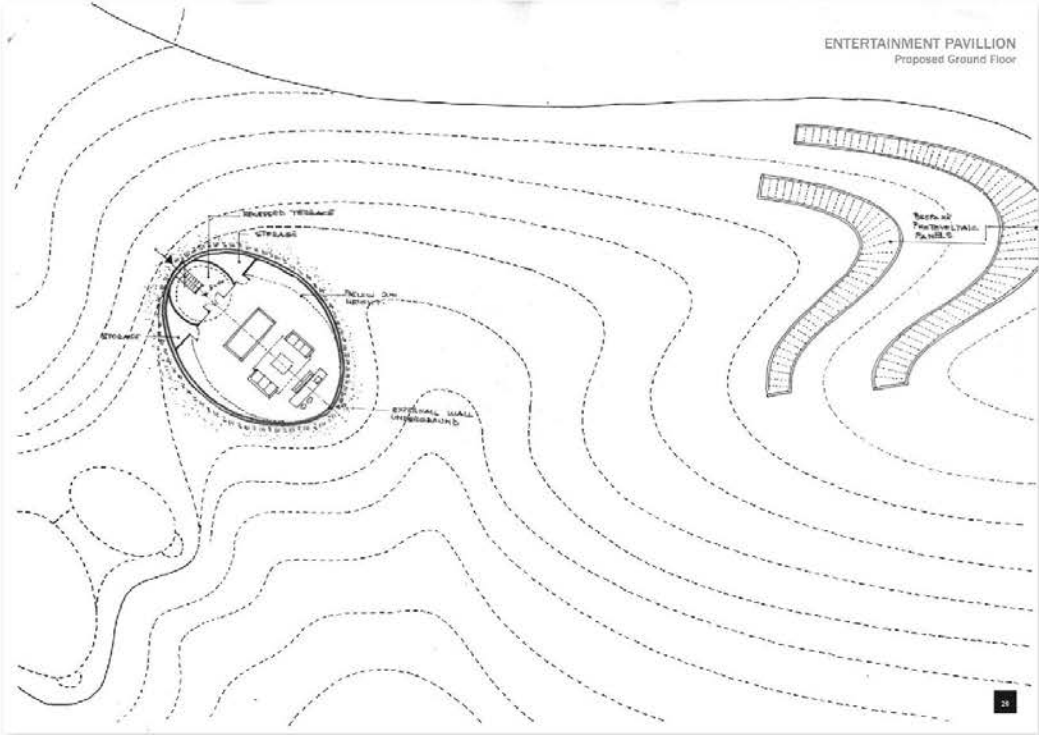

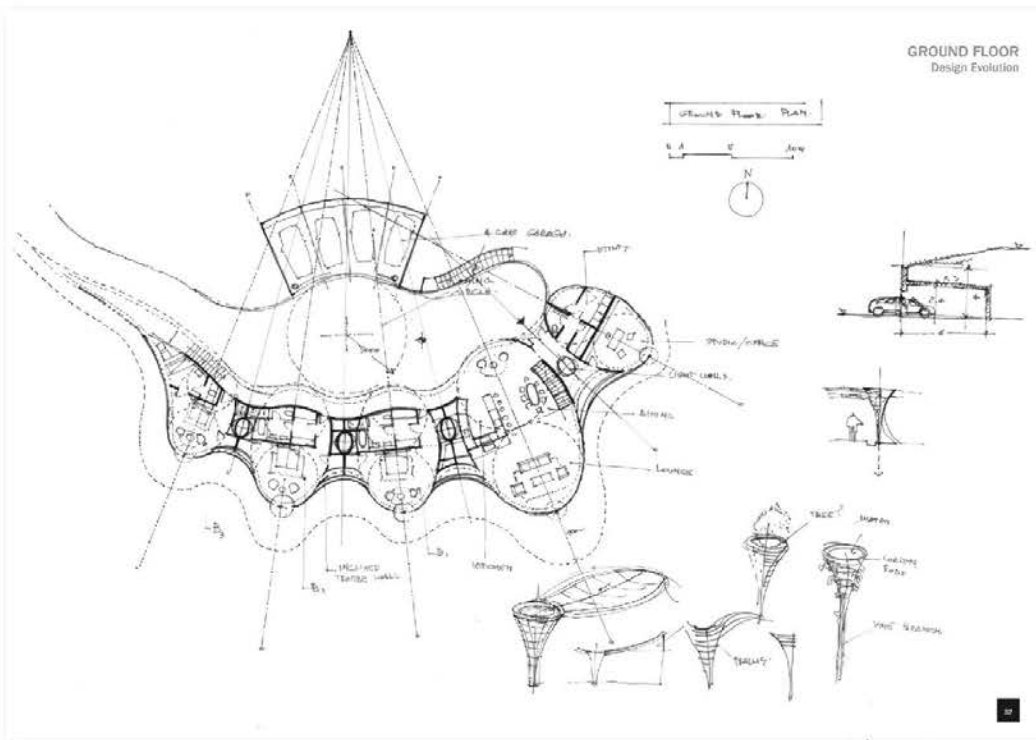

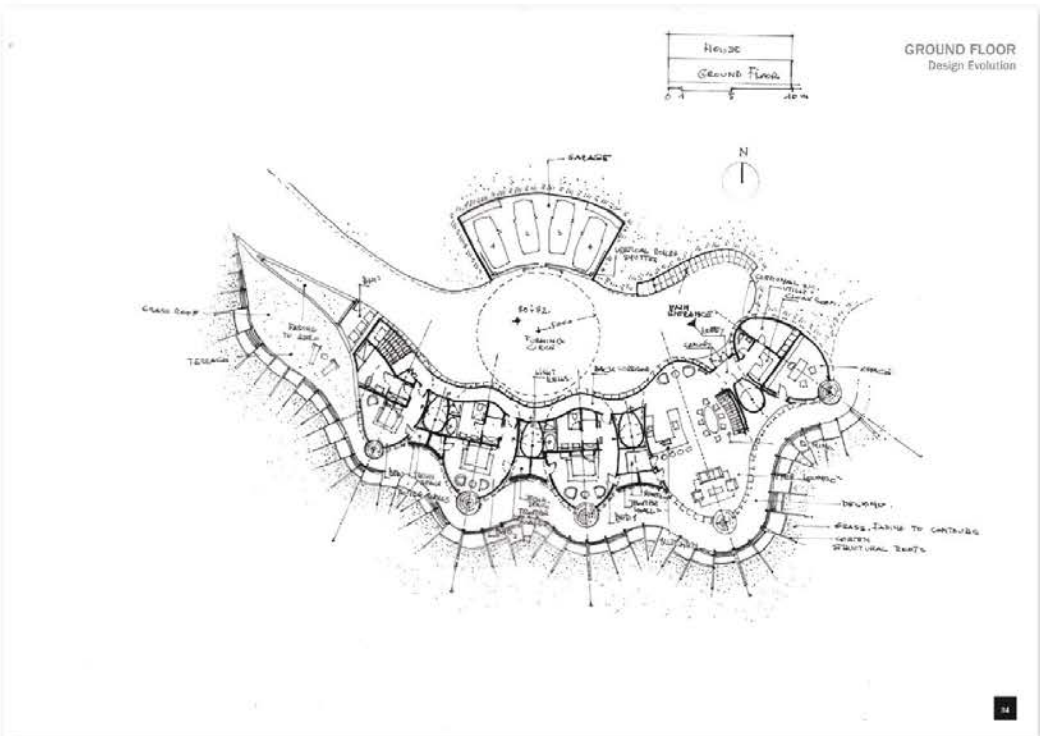
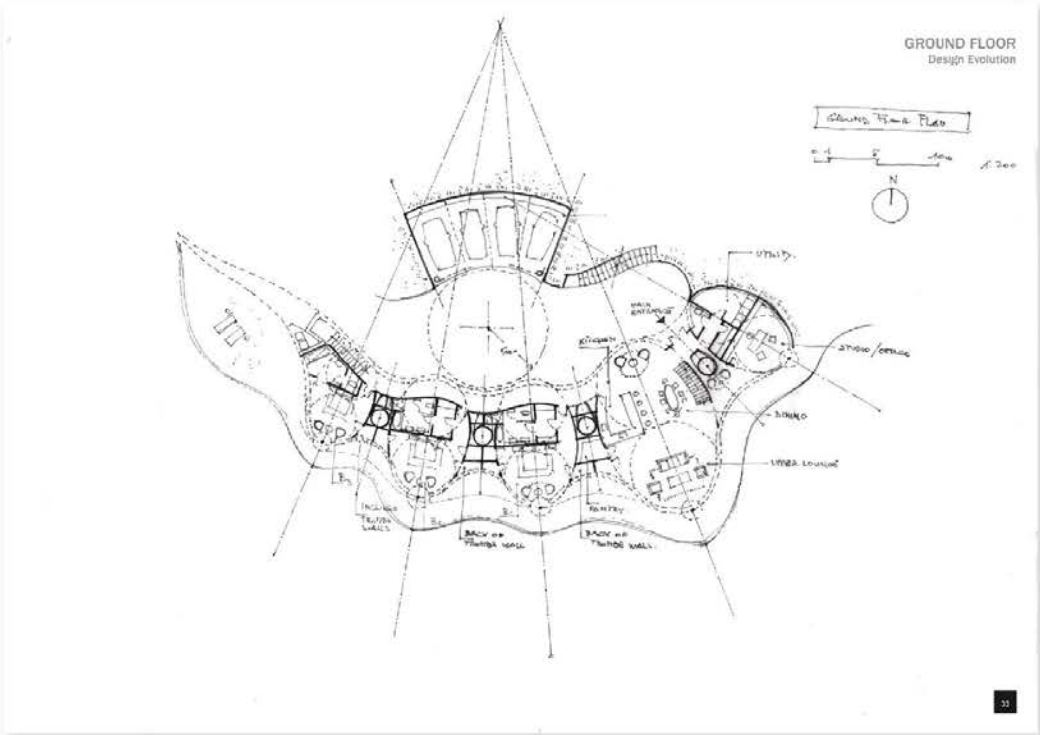

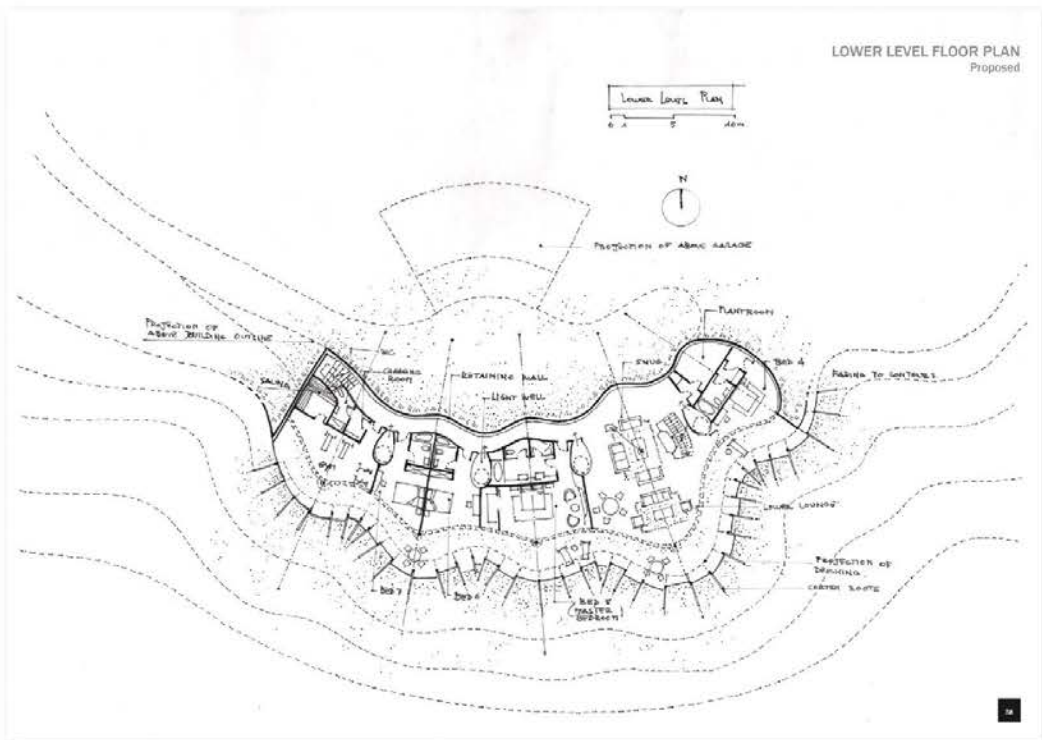
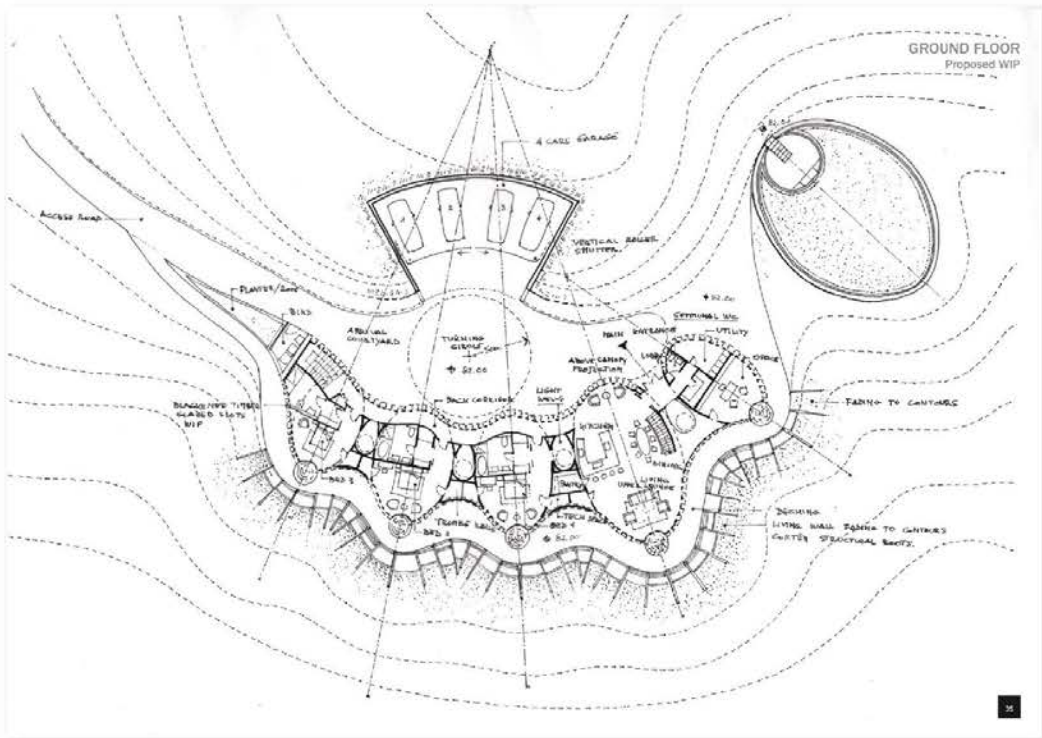

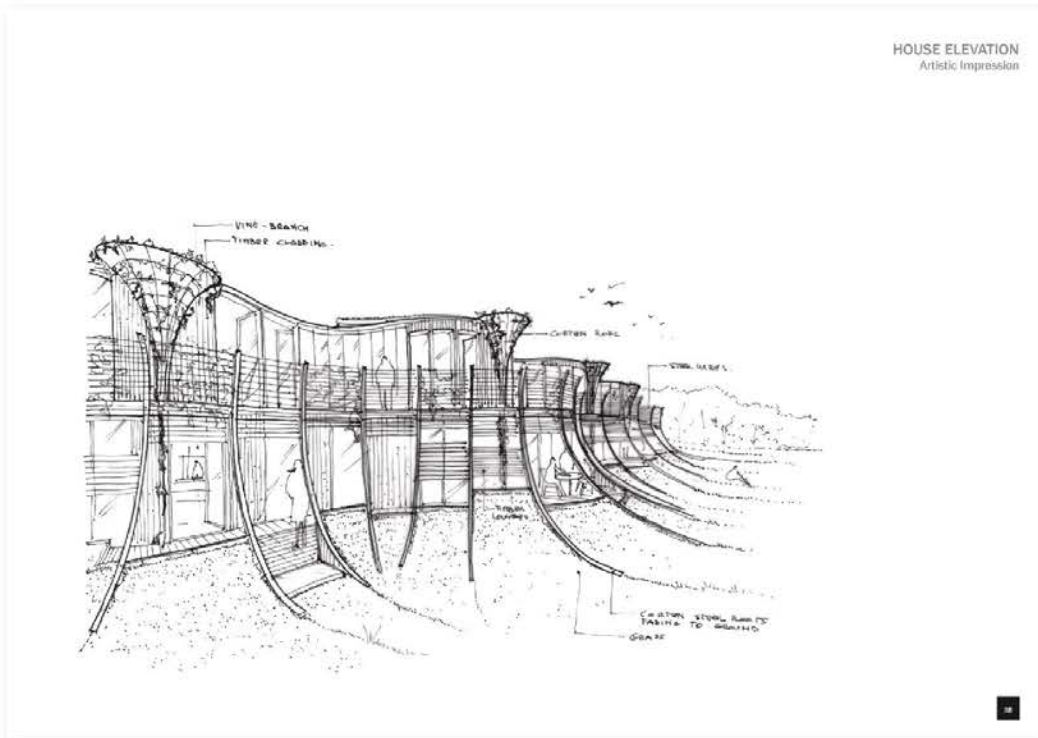
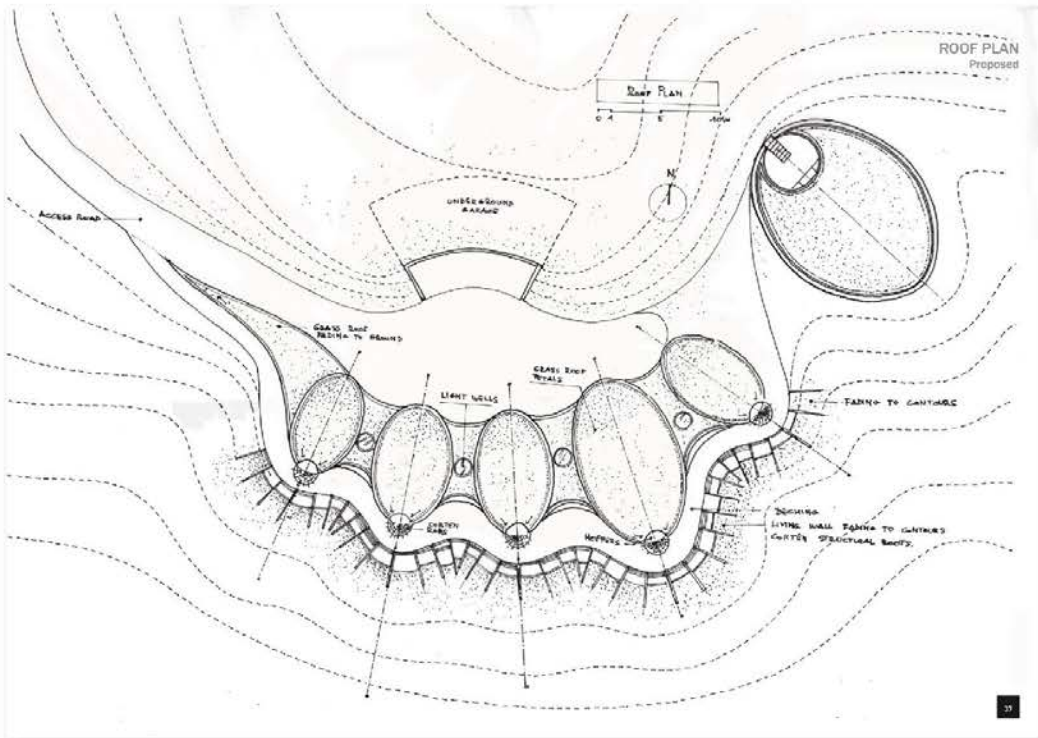

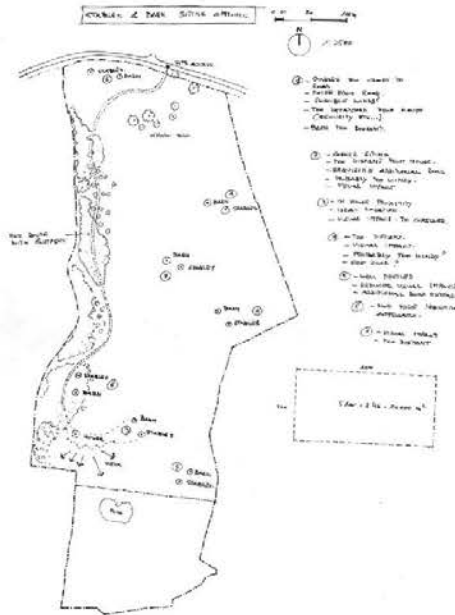

CLUSTER - Option 1  
Initial concepts

CLUSTER OF BUILDINGS  
NOT GREAT ARCHITECTURAL  
ELEMENTS

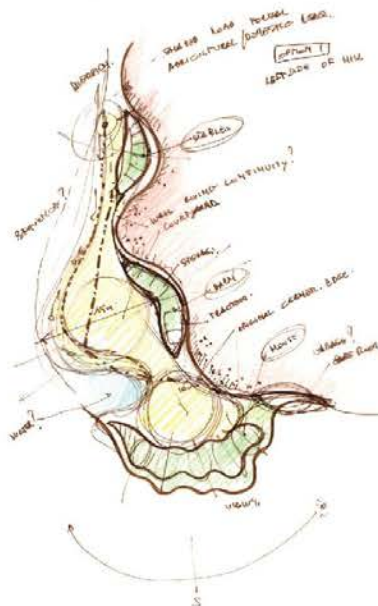

CLUSTER - Option 2  
Initial Concepts

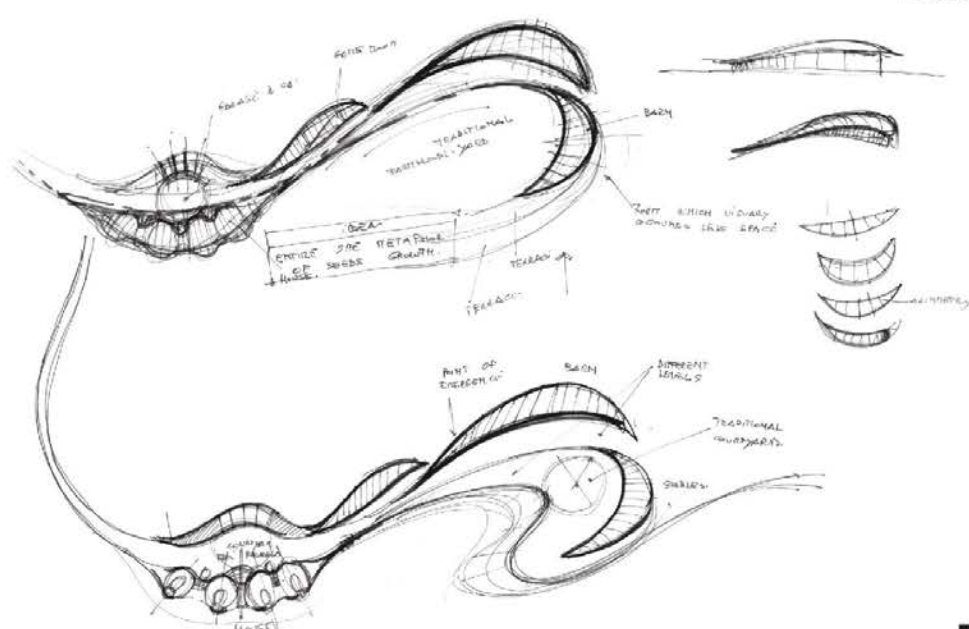



GENERIC BARN DIMENSIONS

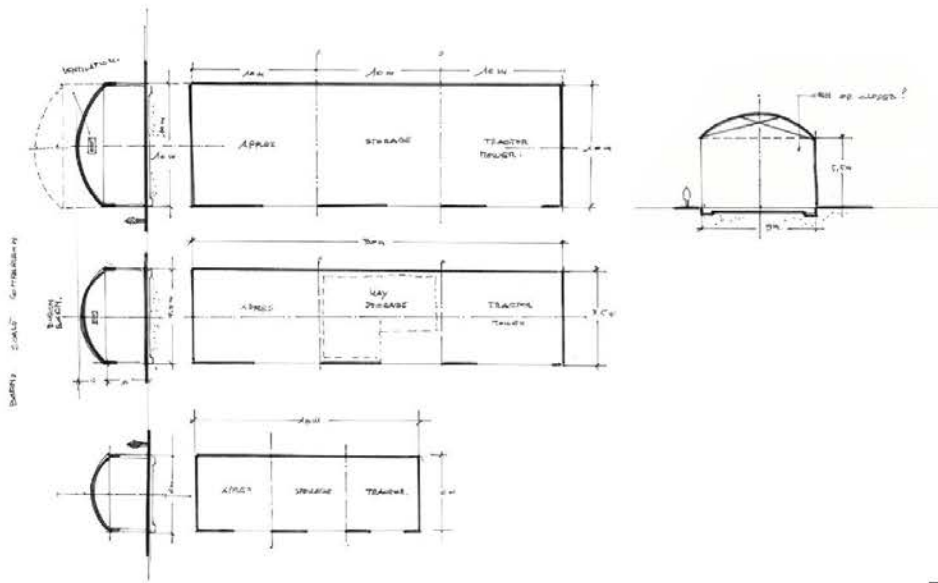

BARN/MUCK HEAP  
Initial concepts

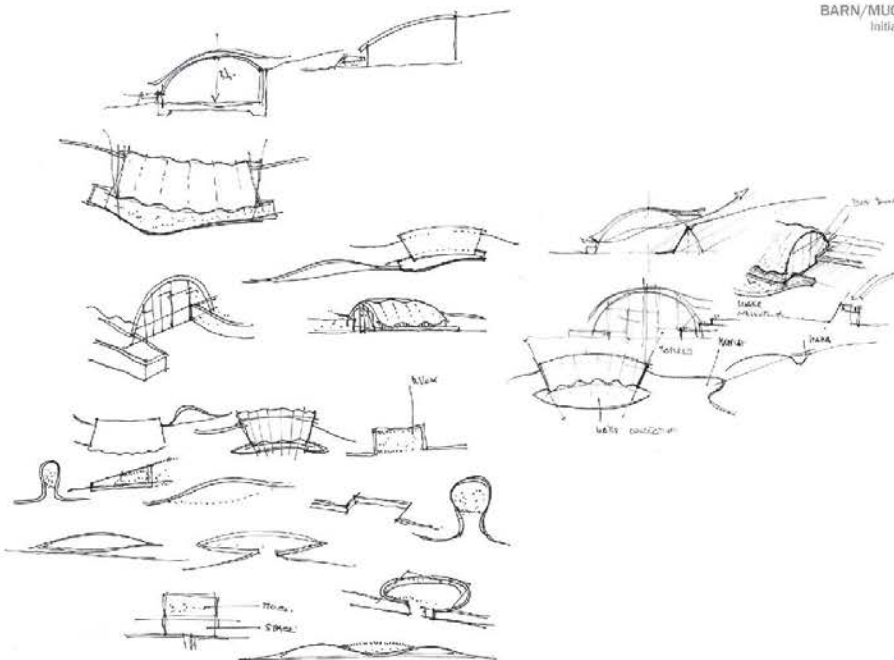

BARN/MUCK HEAP  
Initial concepts

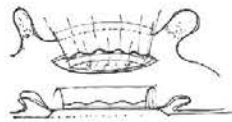
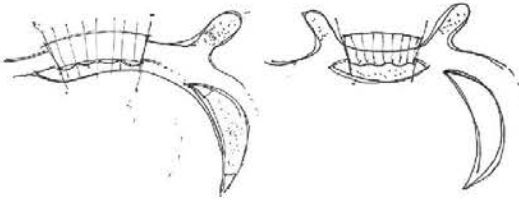
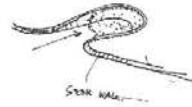
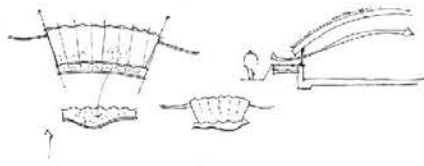
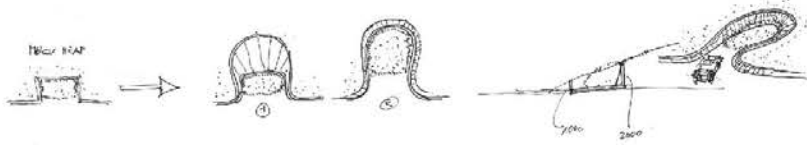

BARN  
Initial concepts

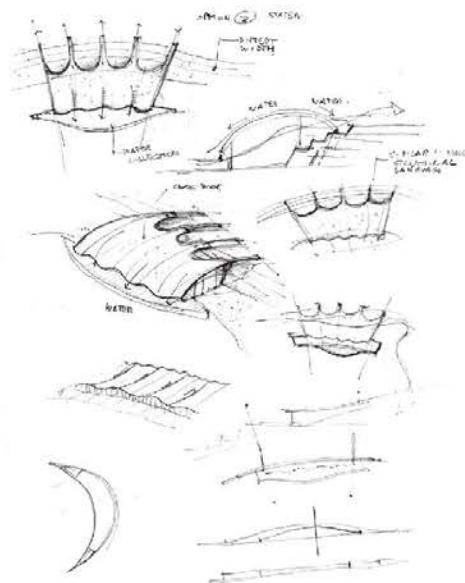
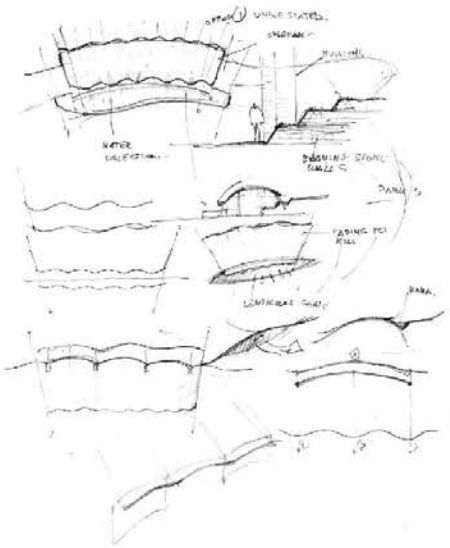

BARN  
Design Evolution

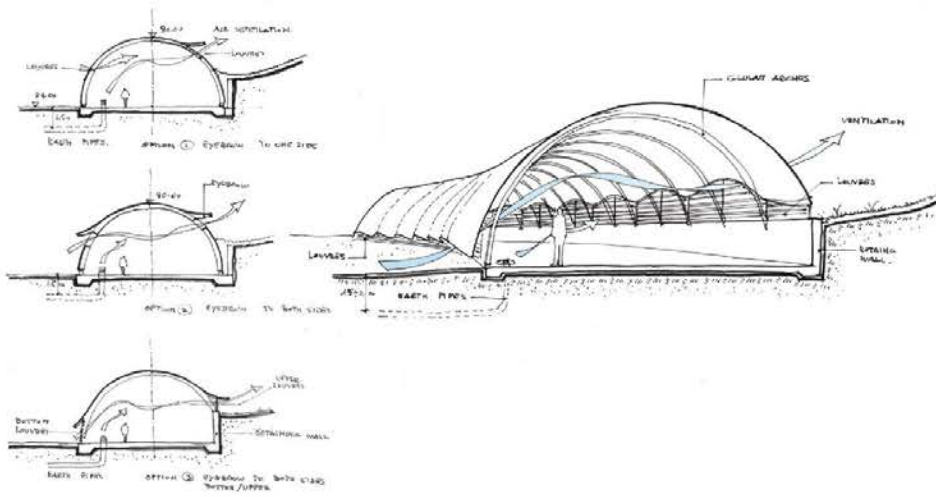

21

STABLES WIP

22



STABLES  
Initial Concepts

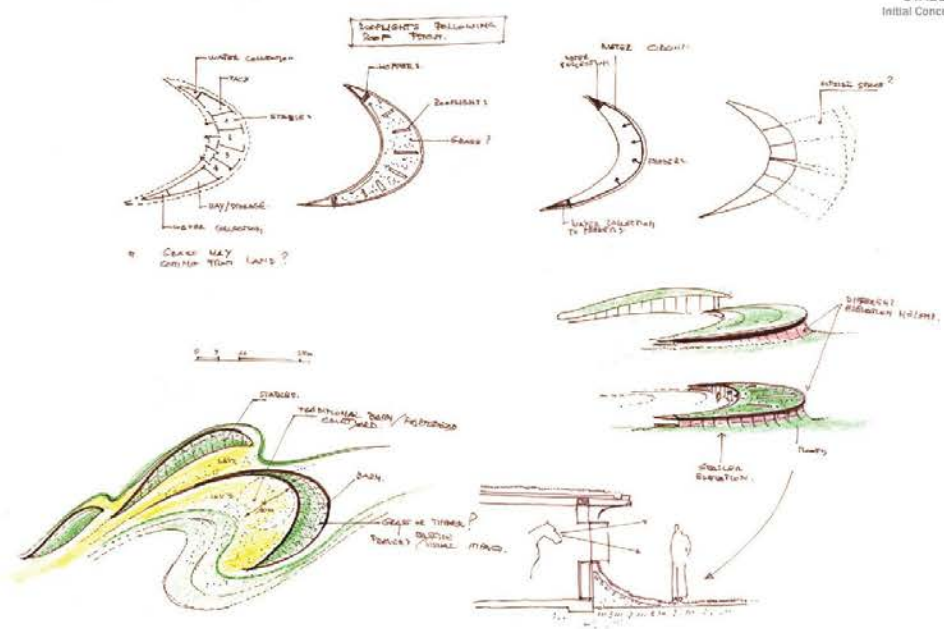

21

HOUSE/FARMSTEAD  
General Arrangement Design Evolution

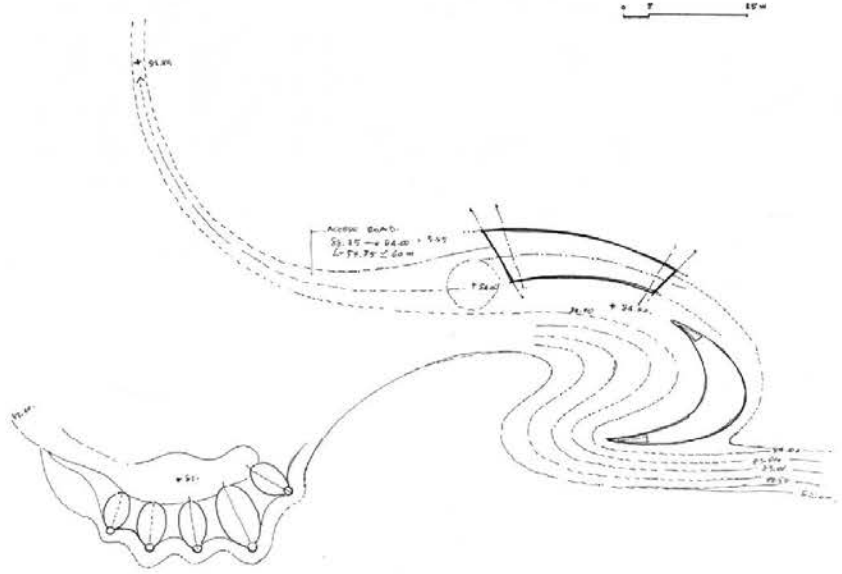

22

BARN/STABLES  
Design Evolution

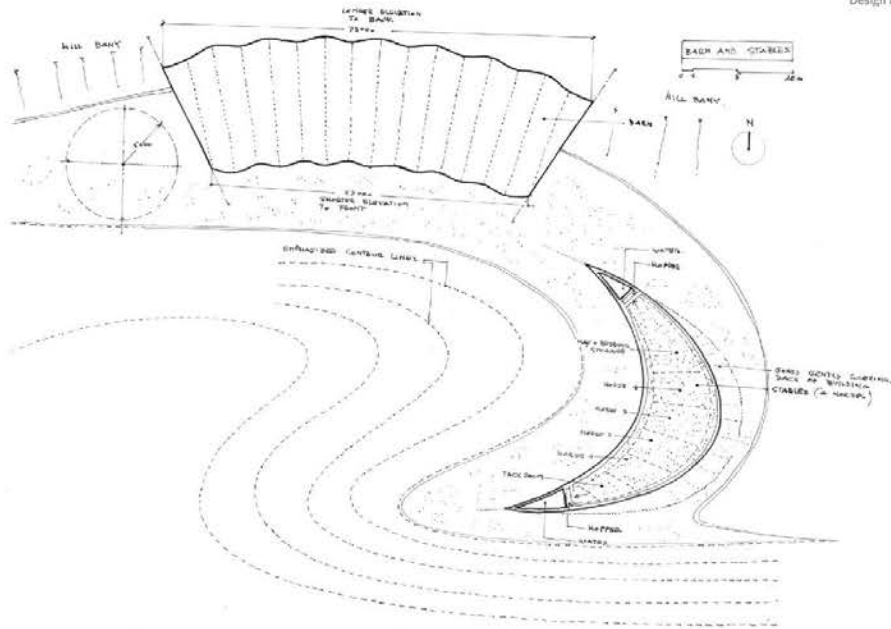

51

BARN/STABLES Floor Plan  
0 5 25 m

BARN/STABLES GROUND FLOOR PLAN  
Proposed

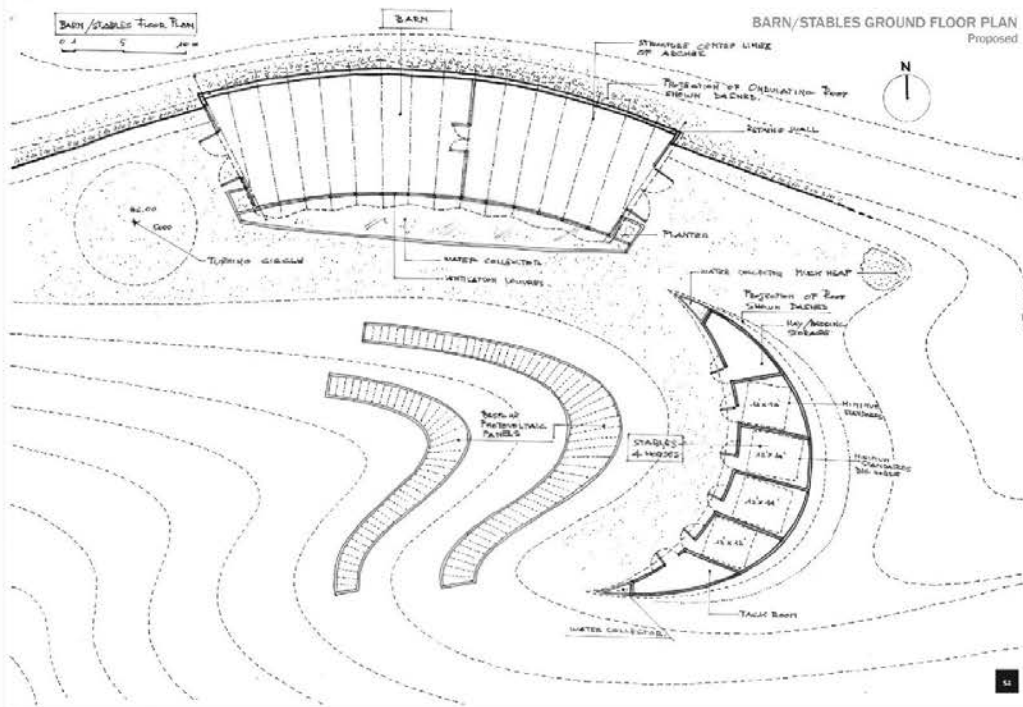

52

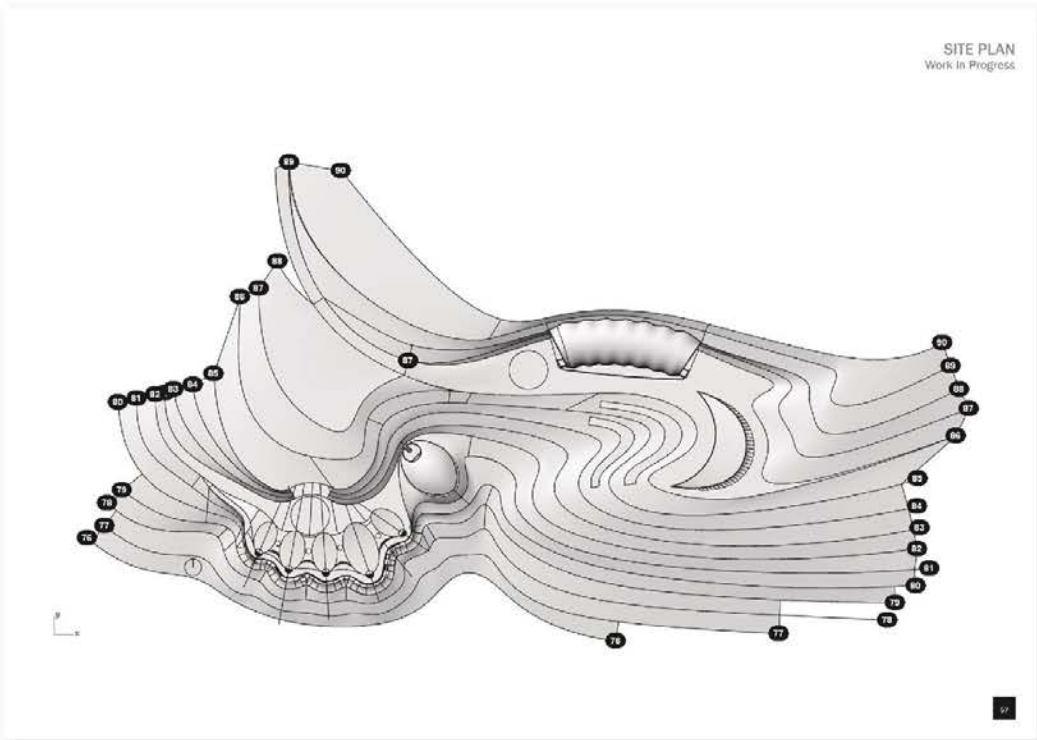

BARN/STABLES AERIAL VIEW  
Work in Progress

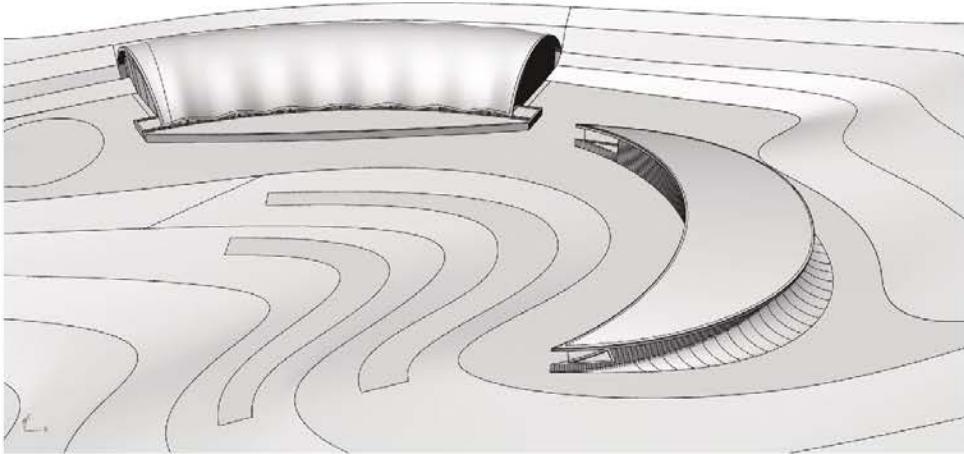

AERIAL VIEW  
Work in Progress

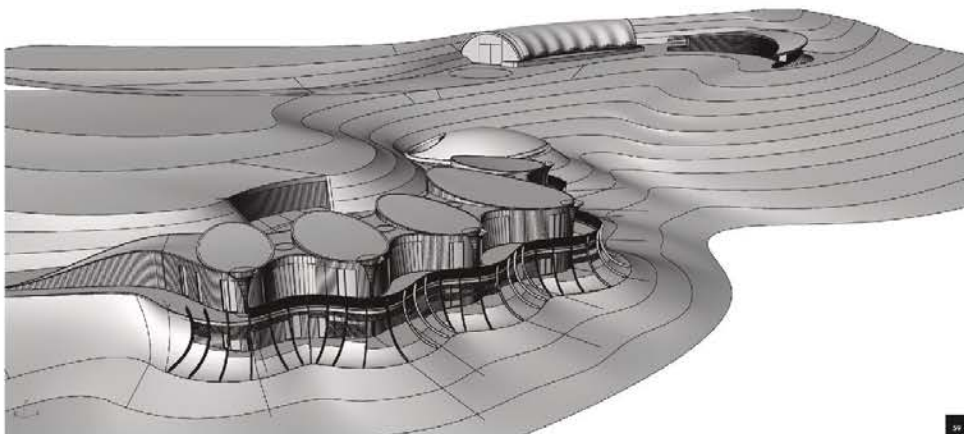





PRECEDENTS  
Green Roofs



PRECEDENTS  
Cloister



PRECEDENTS  
Roots and Climbers



04

PRECEDENTS  
Cladding



05

PRECEDENTS  
Corten





## APPENDIX 4.0 MAY 2018 DESIGN REVIEW FEEDBACK

## Design Review Report

YDRS 206 Ampleforth  
Design Review 2



### Design Review Service for Yorkshire and the Humber

**Status of report:** CONFIDENTIAL  
**Date of Review:** 3 May 2018  
**Location of Review:** New Mesters, Kelham Island, Sheffield, S3 8EN

---

**Scheme Description:** Insertion of a contemporary new home into the landscape to the west of Ampleforth, North Yorkshire.

**Stage of Planning:** Conceptual architectural design.

**Background:** This is the second review of this scheme following the first in November 2017.

**Proposals submitted for Review:** Landscape appraisal, sustainability and innovation and architectural concept brochures were presented.

**Scheme Representatives:** Kevin Brown, Architect, Sadler Brown  
Alex Robinson, Landscape architect, The Landscape Agency

**Panel Members:** Tom Lonsdale, Landscape Architect, Panel Chair  
Ric Blenkarn, Architect

**YDRS Staff:** Jamie Wilde, Yorkshire Design Review Manager  
Robbie Ormrod, Yorkshire Design Review Assistant

---

Supported by



info@integrateplus.com  
www.integrateplus.com

**Summary of panel comments:**

The Panel thanks the project team for returning with this scheme and are happy to see the proposals have progressed well since the first review in November 2017. The project team have done a good job in addressing the comments and guidance from the first review in November 2017.

This is showing signs of developing into one of the best and most interesting Paragraph 55 schemes that the Panel has seen. The Panel endorse the spirit, ethos, landscape strategy and overall response that this scheme brings but the design team must not assume that this will necessarily translate into a planning consent when the Local Authority take into account other policy considerations that are outside this Panel's remit.

The landscape strategy has developed greatly since the first review and the proposals represent genuine and subtle enhancements to the landscape.

More attention could be paid to the proposed ancillary buildings, the stable and barn, to ensure that they complement and to help celebrate the house. At present there is a slight tension between the organic form of the house and the more geometric forms of the secondary buildings.

The following comments are for the project team and local authority's attention.

In summary, these are to focus on the:

- **Landscape Strategy**
- **Architecture**

Supported by



2

info@integreatplus.com  
www.integreatplus.com



Panel comments:

**Landscape Strategy:**

The Panel commend the project team for their work in developing a robust and comprehensive landscape strategy that proposes a mix of new uses to aid the management of the whole site. The strategy is a great response to the ideology of the local area and reinforces the client's long history of agriculture in the village of Ampleforth.

The project team have done well in reassessing the siting of the dwelling to re-establish and justify why its proposed location is the most appropriate response. Maintaining and respecting the VIUA to the north of the site is a sensitive and well-considered approach and results in a house that interacts well with the landscape to the south and is reasonably well screened when viewed from Jerry Carr Bank and Knoll Hill to the north. The analysis of views in and around the local area was very helpful and has helped highlight a pattern of isolated homes and farmsteads. This proposal is in keeping with the results of this analysis and the proposal as a whole represents an innovative reinvention of the farmstead typology.

The Panel applaud the exploitation of the topography of the land to help integrate the house into the landscape. This study of contours has also dictated the pattern of proposed planting of the orchard, which again is admired by the Panel. Better visual representation of the contours on a large plan will help to demonstrate this.

A concern from the first review was the length of the access road to the house. The inclusion of new uses on site help to justify this, forming a shared, multi-functional route with secondary circulation to serve the new land uses. It is suggested that the driveway is not overworked and is detailed as an honest and unpretentious response to the existing terrain. The experience of the journey through the site with its proposed planting and utilisation of topography could be great if it is executed as well as it is in plan.

The Panel welcome the revision to the wetland boundary and its overall strategy to encourage and stimulate wildlife and biodiversity in this part of the site. Perhaps discussions with Natural England will help establish if there are any target species that could be introduced or favoured in the management.

The removal of some planting from the first proposal to the south of the site is welcomed and will treat people using the public right of way with interesting views and glimpses of the house.

Refining the transitional area of land between the house, barn and stables could give this space some more clarity and identity, which presently displays some ambiguity about whether it is garden, farmyard or cultivated area.

The overall strategy including the sub-division of fields and habitat introduction is generous and beneficial to the landscape and immediate setting. Whilst the site is not obviously and seriously degraded to the degree seen in some other Paragraph 55 schemes reviewed by this Panel, it is worth reiterating that the historic loss of hedgerows and monoculture management of the resulting large field has detracted significantly from the landscape character of the area. The apple production and equestrian uses returning under this scheme, with the attendant infrastructure and management, will restore a character and personality to the site with genuine relevance to Ampleforth.

Supported by



3

info@integreatplus.com  
www.integreatplus.com

### **Architecture:**

The Panel feel there is a real poetry with the house and the way it is borne out of the land. The architectural proposal for the house represents an impressive and fascinating manifestation of the initial concept.

The introduction of functional buildings such as the barn and stables are a sensible and plausible inclusion which is driven by the client's family needs. Individually, these are well designed, but the Panel notice some tension and conflict between the organic form of the house and the more geometric barn and stable. Although it is understood these are functional buildings which are shaped by their intended uses, the design team could revisit these elements to see if there is a more harmonious response which plays down the prominence of the barn and stable and helps to celebrate the house. Perhaps a continuation of topographical exploitation could inform better integration of these two buildings and result in more organic forms. The Panel recognise that they have not seen these buildings with the proposed green roofs, which may contribute to achieving a more natural and organic feel.

The Panel feel there is a slight disconnect between the organic flow of the house and the mechanical cloister. More thinking is encouraged about how this cloister could be revised or removed, perhaps thinking of other ways the building could celebrate views of the landscape without feeling constrained by the cloister. The sketches and visuals show a very natural and organic form very well, however the cloister loses some of this form.

The south elevation could do with more work to give it the robustness of the plan, thinking more about the canopy roof and how this could be better conveyed in elevations and again in later proposals.

The Panel agree that a 3D printed model would be a great addition to help communicate how well the building fits into the landscape. This is a very distinctive and unique proposal, many people won't have seen anything like this before, and so a model should help demonstrate its quality.

In general this is a very exciting proposal that just needs a little more refinement and detailing. It is already innovative in its design approach with the potential to be considered outstanding once the detailing is executed to the same standard.

Supported by



**Please note:**

- If the subject of this review is a scheme that has been submitted for planning consent, the review findings will be published on the Yorkshire Design Review Service/Integreat Plus website and made available to the relevant Planning Committee. Otherwise, this report will be treated as confidential to the parties present at the Review.
- The Yorkshire Design Review Service is advisory and independent and has no statutory status although aims to add value to the planning process. The Design Review Service advises objectively on schemes regardless of whether they are funded or supported by Integreat Plus or other partner organisations. The views recorded are not formally endorsed by Integreat Plus and do not amount to the provision of a service by the YDRS to the scheme representatives or create an advisor-client relationship.

---

Report drafted by Jamie Wilde, Yorkshire Design Review Service Manager

Checked and approved by Tom Lonsdale, Panel Chair

Issued: 10th May 2018

Supported by



5

info@integreatplus.com  
www.integreatplus.com

**SADLER BROWN ARCHITECTURE**

11/12 Riverside Studios  
Amethyst Road  
Newcastle upon Tyne  
Tyne and Wear  
NE4 7YL

T: +44 (0) 191 265 7080  
E: [info@sadlerbrown.co.uk](mailto:info@sadlerbrown.co.uk)  
[www.sadlerbrown.co.uk](http://www.sadlerbrown.co.uk)